



**48TH ANNUAL IAOM
LATIN AMERICA REGION
CONFERENCE & EXPO**

**FEBRUARY 3-5, 2025
DOUBLETREE BOGOTÁ SALITRE AR
BOGOTÁ, COLOMBIA**

2025 EXHIBITOR PROSPECTUS

SHOWCASE YOUR EXPERTISE AND SOLUTIONS AT THE 48TH ANNUAL IAOM LATIN AMERICA REGION CONFERENCE & EXPO

IAOM Profile

Since its founding in 1896, the International Association of Operative Millers (IAOM) has been the premier provider of educational resources and training for the global grain milling industry. Through conferences, workshops, courses, and publications, IAOM has supported the professional development of millers for more than 120 years.

IAOM's membership of over 1,800 professionals spans more than 100 countries, providing an international platform for networking, knowledge sharing, and the discovery of innovative products and services. With 12 districts in North America and 4 international regions, IAOM continues to be a key driver of industry growth and success.

Why Exhibit at the IAOM Expo?

Maximize Your Investment: In just two days, your team can achieve months of sales outreach by connecting with decision-makers, forging valuable relationships, and expanding your network.

Showcase Innovation: IAOM expos are where industry professionals turn to stay updated on the latest trends. Use this platform to introduce new products and services and gain immediate feedback from potential clients.

Enhance Your Brand Visibility: Exhibiting at IAOM offers unparalleled name recognition among top milling companies worldwide, reinforcing your brand as an industry leader.

Expand to New Markets: At the 48th annual conference, your company will have the opportunity to enter new markets while benefiting from the familiar and trusted IAOM event structure.

Traffic Generating Features

Refreshment Breaks in Exhibition Area: Scheduled breaks on Tuesday and Wednesday to drive traffic directly to your booth.

Raffles and Giveaways: Increase engagement by participating in product raffles and giveaways. Exhibitors hosting raffles will be featured in a flyer distributed to attendees. Raffle winners will be announced on Wednesday at 11 a.m. by representatives from each booth.

Exhibit Hall Information

Tabletop Display Rental: \$1,200 per table

(Tables reserved for Platinum Sponsors will be marked.)

All displayed products must fit on the table provided.

Exhibit Fees Include:

- Table with drape (180 cm x 75 cm) and two chairs
- Company name in the official conference program and on the mobile app
- Listing on the IAOM website
- Discounted advertising rates in IAOM publications
- Two complimentary conference registrations per table
- Opportunity to introduce new products/services during the What's New session
- Complimentary conference access for two milling customers

Exhibitor Benefits

- Over 3.5 hours of unopposed exhibition time
- High visibility with key decision-makers in the industry
- Access to educational sessions
- Recognition in conference promotional materials

Floor Plan

Exit Door

Exit Door

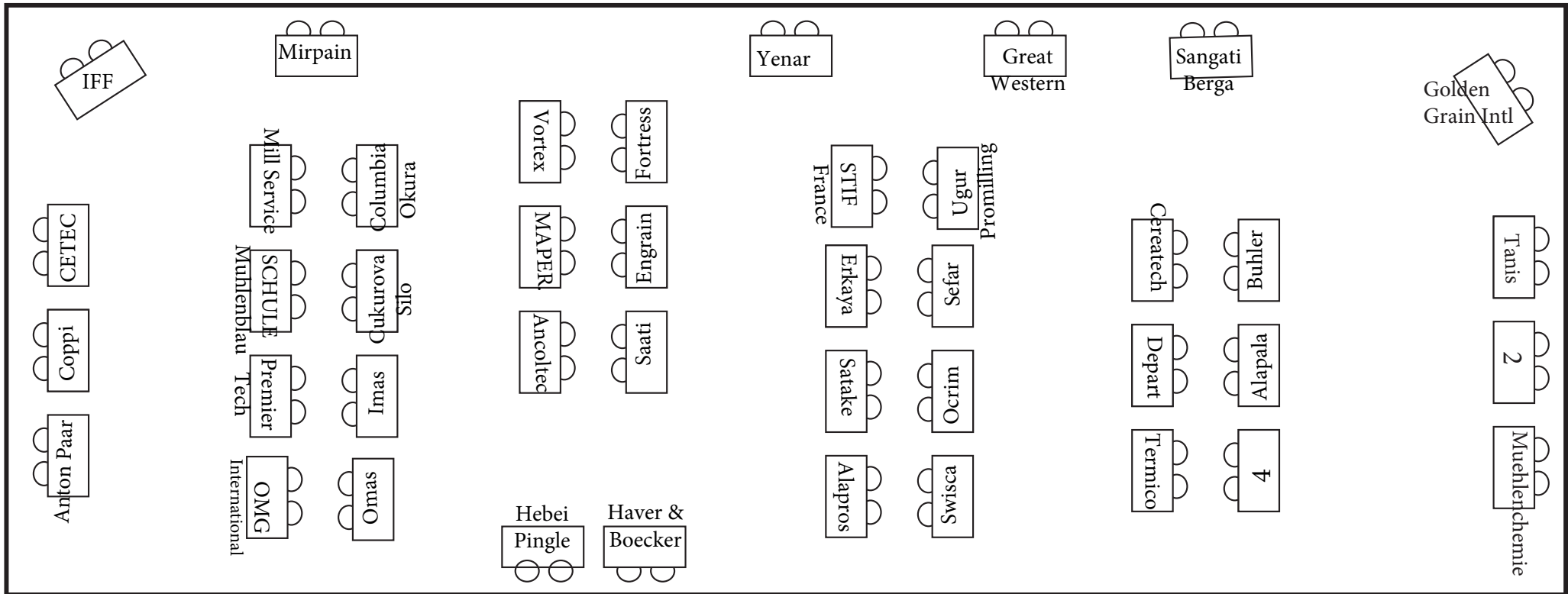

Entrance

Entrance

Coffee Breaks and Main Entrance

TABLES 1-6 - RESERVED
FOR PLATINUM SPONSORS

APPLICATION PROCEDURES AND SPACE REASSIGNMENTS

The Association reserves the right to determine the location of table assignments. Consideration will be given to applicant's participation in prior expositions and the date of receipt of the application in the IAOM office. Companies should be aware that prime space is typically assigned to companies that have a longer exhibit history. The floor plan has been designed to maximize the amount of exhibit space in conjunction with the Association's own needs on the exhibit floor. IAOM reserves the right to modify the exhibit hall floor plan, as necessary, to meet the needs of exhibitors, IAOM and the expo. ***Only registered attendees with an official conference badge will be admitted to Educational Sessions and the Expo. There will be no Expo-only passes or conference access for local distributors of exhibiting companies.***

All exhibiting companies will need to register staff individually using the discount code provided to you by IAOM. Discount codes will be sent to the primary contact once the Exhibitor contract has been submitted and processed by IAOM.

Application for exhibit space must be made in writing and include a completed contract and total amount due. Review the floor plan and indicate on the contract three (3) preferred locations for your exhibit. Table selection and exhibitor registration are also available at www.iaom.org/latinamerica. New contracts will not be honored until all past due invoices with IAOM have been paid.

Rental fee includes one table, two chairs, uniform identification sign and two complimentary conference registrations. For additional equipment, please contact Whitney Fox at DME@iaom.org.

EXHIBITOR CONTRACT

The undersigned exhibitor agrees to rent and occupy _____ table top display(s) as shown on the official floor plan from IAOM during the 2025 LA Expo. The undersigned further agrees to abide by the Rules and Regulations stated on this contract and to pay a rental fee in US dollars of \$_____ when the contract is submitted. Rental must be paid in full by January 10, 2025. If the invoice isn't paid in full by January 10, 2025, the selected booth will be released and the company will be contacted in priority-point order to reselect a booth space.

ACCEPTANCE AS BINDING CONTRACT:

Company Name _____ Primary Contact _____
E-mail _____ Address _____
City _____ State/Province _____ Zip _____ Country _____ Phone _____
Website Address _____

Signature by Authorized Representative _____

Date _____

By signature above, the individual signing this contract represents and warrants that he/she is duly authorized to execute this binding contract on behalf of named Exhibitor.

COMPANY PROFILE: Please attach company profile (50-word limit) as it will appear in the official conference program (if received prior to January 10, 2025) to

DME@iaom.org

NAME OF COMPANY EMPLOYEE WHO IS AN IAOM MEMBER IN GOOD STANDING : _____

TABLE TOP RENTAL FEES: IAOM MEMBER RATES: Each Table: \$1,200 USD

NONMEMBER RATES: Those exhibitors that do not have an employee who is an IAOM member in good standing will be charged an additional \$100 per booth.

Please list the company(s) you would NOT want to be near : _____ Please indicate your first three table choices here

Billing Contact (if different from above): Name _____ 1 _____ 2 _____ 3 _____

Phone _____ E-mail _____ The rental fee paid includes 1 table, 2 chairs and a uniform identification sign.

Address _____ City _____ State/Province _____ Zip _____

METHOD OF PAYMENT:

Check enclosed (Payable to IAOM, US funds only) Charge to following credit card: VISA MC Discover American Express

Card No. _____ Expiration Date ____/____/____ Cardholder Name _____

CVV: _____ Cardholder Signature _____ Date Signed _____ Total \$ _____

Wire Transfer

Contact IAOM for bank details.

Please mail all checks and a copy of signed contract to:

IAOM
12351 W. 96th Terrace, Suite 100
Lenexa, KS 66215
Email: DME@iaom.org

Sponsorship Package (includes exhibition table)

Platinum - \$5,000 Silver - \$3,000

Gold - \$4,000 Bronze - \$2,500

If you would like to participate in the Exhibitor Raffle, please send the following information to IAOM by January 10, 2025, at IAOM: by email: DME@iaom.org or fax: 913-338-3553.

Exhibitor: _____ Booth number: _____

Raffle Prize/Giveaway: _____

Contact person: _____ Contact at the show: _____

SPONSORSHIP OPPORTUNITIES

Enhance your presence at the 48th Annual IAOM Latin America Region Conference & Expo by exploring high-impact sponsorship options. This premier educational event offers the perfect setting to showcase your company's products and services to grain milling and processing professionals.

As an IAOM Sponsor, your company earns very tangible special benefits. Four different sponsorship levels are available:

BENEFITS

	PLATINUM (limit 6)	GOLD	SILVER	BRONZE
Exhibition Table	✓	✓	✓	✓
Additional complimentary registrations for exhibiting sponsors	1	0	0	0
Sponsor ribbon for all registered staff of sponsoring company	✓	✓	✓	✓
Sponsor acknowledgment on the official conference website	✓	✓	✓	✓
Listing in conference program	✓	✓	✓	✓
Special IAOM Certificate of Appreciation	✓	✓	✓	✓
Listing in conference program with logo	✓	✓		
Hyperlink from official conference website to Sponsor's URL	✓	✓		
Company PowerPoint slides (up to 10) displayed during breaks	✓			
Exhibition table in prime location	✓			
Identified as Reception sponsor	✓			
Free conference access for 2 of your milling customers (4 total)	✓			
Acknowledgment of sponsorship on social media	✓			

BUILD NAME RECOGNITION: Showcase your company and products to over 100 international milling industry professionals, solidifying your brand within the global marketplace.

MAXIMIZE VISIBILITY: Expand your reach beyond the exhibit hall with opportunities to gain exposure throughout the entire meeting, ensuring attendees remember your brand.

SUPPORT THE INDUSTRY: Demonstrate your company's commitment to the milling industry and education by backing this premier event, reinforcing your position as a key partner.

PROMOTE INNOVATION: Highlight your latest technological advancements and research, positioning your company as a leader in the field.

EXHIBITOR RAFFLE

We encourage all exhibitors to participate in the Exhibitor Raffle, held on Wednesday at 11 a.m. This event is designed to keep attendees engaged through the end of the expo. Here's how to participate:

- Supply a raffle prize (anything from products and services to event tickets or gift certificates).
- Collect entries from attendees using business cards or entry forms.
- Announce your winner at the end of the expo (the winner must be present and an IAOM member).
- Exhibitors conducting raffles will be invited to the microphone to announce their prize winners, keeping the crowd engaged and promoting your brand until the expo concludes.

Raffle prize information must be submitted to IAOM by **January 10, 2025**, to be included in the program.

For more information or to secure your spot as an exhibitor, contact IAOM at dme@iaom.org or visit iaom.org/latinamerica.

