



# Kice Dust Control System Design and Maintenance Basics

Design, Maintenance, & Operation

**Kurt Meyers**  
September 18, 2014

[kice.com](http://kice.com)

©Kice Industries, Inc. All rights reserved.



## Topics of Discussion

- Why and Where do we need Dust Control?
- System Design Objectives
- Design of a Dust Control System
- Component Review
- Dust Control Troubleshooting
- Dust Control Maintenance
- Explosion Protection
- Questions



©Kice Industries, Inc. All rights reserved.



### Why is “Dust” a Problem?

- Product degradation or loss
- Health issue for workers
- Safety issue for assets and facilities
- Sanitation and infestation control
- Maintenance
- Equipment life expectancy
- Retention of valuable product

### Where is “Dust” a Problem

- Anywhere in a facility – product transfer, pit dumping, loadout, tunnels, head house, aeration, even in the offices.

©Kice Industries, Inc. All rights reserved.



### Solutions for “Dust Control”

“An efficient dust-control program in a grain elevator has three parts: mechanical housekeeping, manual housekeeping, and methods for minimizing the generation of dust.”

*- Pneumatic Dust Control in Grain Elevators, 1982, Publication NMAB 367-3  
National Materials Advisory Board*

- General suction system (Cyclone and/or Baghouse Filter)
- Central Vacuum System
- Grain cleaning (before it brought into the facility)

### Expectations of a “Dust Control System”?

- Reduce fugitive dust inside facility and on equipment
- Protect the assets (people, equipment and facilities)
- Reduce the “tracking of dust” everywhere
- Increase storage capacity
- Reduce potential for explosions
- Better product flow ability

©Kice Industries, Inc. All rights reserved.



# System Design Objectives

©Kice Industries, Inc. All rights reserved.



## Pick up point design

- The containment of dust
  - *Dust systems work the best with properly designed dust hoods to contain the dust.*
- The capture of dust
  - *Suction hood*
    - Proper location
      - *Close to dust source*
      - *Take advantage of natural air currents*
      - *Must not interfere with operation or maintenance*
    - Adequate air
    - Low face velocity

©Kice Industries, Inc. All rights reserved.



## Good Velocity, Good Volume, Good Design

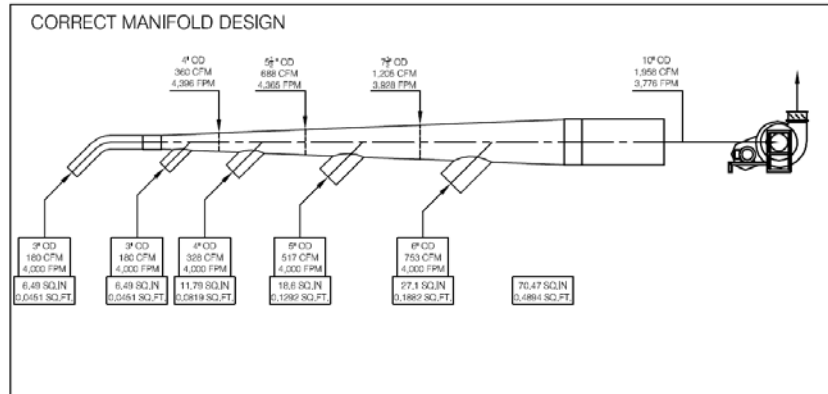

- Dust is in suspension because of correct velocities.

©Kice Industries, Inc. All rights reserved.



## Typical Dust Control System

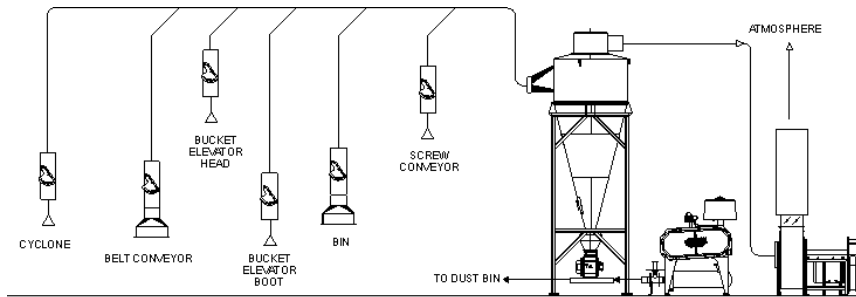

Basic system equipment list: hoods, dampers, cyclone and suction fan

**Options:**

- Replace cyclone with baghouse filter
- Replace pressure convey system to dust bin with container

©Kice Industries, Inc. All rights reserved.



# System Design

©Kice Industries, Inc. All rights reserved.



## General Good Installation Practices

- Increase line as needed to size to keep good velocity in the line back to the filter
  - *Reduces resistance*
  - *Keeps dust in suspension*
- Use lockable dampers or slide gates on each connection point
  - *Use for balancing*
  - *Then lockout to keep from changes being made*
- Allow Free Air into the system
  - *Cannot "pull" against a dead head or sealed system*
  - *Allows air to be pulled into the system*
  - *Make use of natural air currents*

©Kice Industries, Inc. All rights reserved.



## General Good Installation Practices

- Seal any “leaks” in the system
  - *Will rob the dust collection system of suction to remove dust*
  - *Small leak may not be an issue, but many small leaks will add up*
- Turn laterals on side and then drop down
  - *If turned down, will fill with dust and clog*
  - *If turned on side and then down, will keep line clear*
- Purchase and learn to use an Air Measuring Kit
  - *Will let you measure resistance and static pressure*
  - *Will let you balance a system*
  - *Will let you set standards to follow*

©Kice Industries, Inc. All rights reserved.

## Typical Kice Air Measuring Kit



©Kice Industries, Inc. All rights reserved.



## Minimum Duct Design Velocities

Nature of Contaminant	Examples	Minimum Design Velocity, fpm
Vapors, gases, smoke	All vapors, gases, smoke	1000 - 2000
Fumes	Welding	2000 - 2500
Very fine light dust	Fine rubber dust, cotton dust, bakelite molding powder dust, jute lint, cotton dust, shavings (light), soap dust, leather shavings	3000 - 4000

For Grain Dust: 3400-4000 FPM



## Bad Velocity, Good Volume, Bad Design

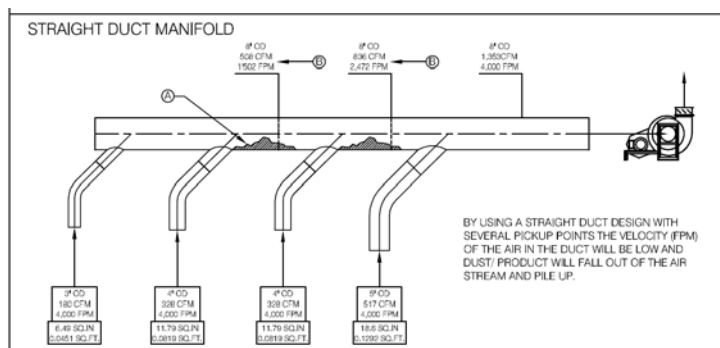

- Dust is dropping out (in locations)
- System is balanced (at end of system).

## Additions without Rebalancing

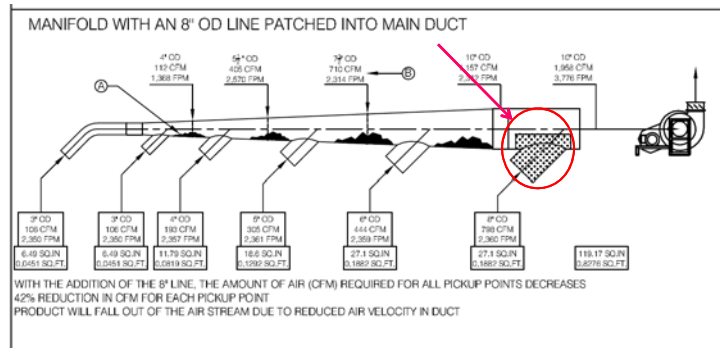

- Duct is NOT in suspension because the system is not balanced.
- Air taking path of least resistance.

## Deductions without Rebalancing

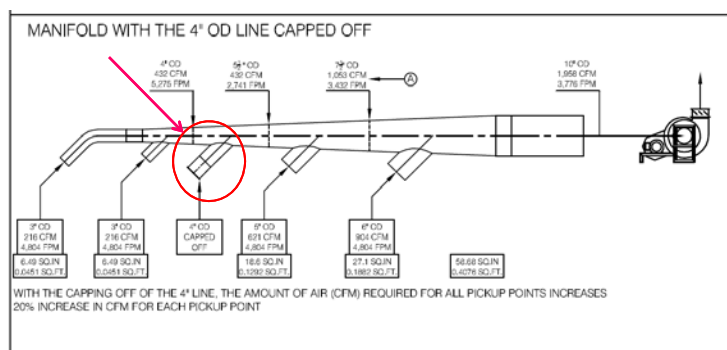

- Dust is in suspension (but at higher velocity); System is not balanced.
- System works but wasting energy (HP)



# Tube Data Chart



We make your job easier. Today.

TUBE DATA CHART

Tube		Area		Velocity Feet Per Min.								90° EL Equiv. Ft.
O.D.	I.D.	SQ. IN.	SQ. FT.	3600 @ .81 wg		4000 @ 1.0 wg		4400 @ 1.21 wg		4800 @ 1.44 wg		
				C.F.M.	IN. PER 100'	C.F.M.	IN. PER 100'	C.F.M.	IN. PER 100'	C.F.M.	IN. PER 100'	
1.5	1.375	1.48	.0103	37	15.0"	41	18.0"	45	22.0"	49	27.0"	4'
2	1.875	2.76	.0192	69	10.5"	77	13.0"	84	15.0"	92	17.5"	5'
2.5	2.375	4.43	.0308	111	7.8"	123	9.5"	136	11.2"	148	13.0"	6'
3	2.875	6.49	.0451	162	6.2"	180	7.5"	198	9.0"	216	10.0"	8'
3.5	3.375	8.95	.0621	224	5.2"	248	6.3"	273	7.5"	298	8.5"	9'
4	3.875	11.79	.0819	295	4.3"	328	5.3"	360	6.4"	393	7.0"	10'
4.5	4.375	15.02	.1043	376	3.7"	418	4.6"	459	5.2"	501	6.3"	11'
5	4.875	18.6	.1292	465	3.2"	517	4.0"	568	4.8"	620	5.2"	12'
5.5	5.375	22.7	.1576	567	3.0"	60	3.7"	693	4.3"	756	4.4"	14'
6	5.875	27.1	.1882	678	2.7"	753	3.3"	829	3.9"	904	4.2"	15'
8	7.875	48.7	.3382	1218	1.9"	1353	2.3"	1488	2.7"	1623	3.0"	20'
10	9.75	74.66	.5185	1867	1.4"	2074	1.7"	2281	2.1"	2489	2.5"	25'
12	11.75	108.43	.7530	2711	1.2"	3012	1.4"	3313	1.7"	3614	2.0"	30'

Tube I.D. and area based on .063 wall thickness, except 10" or 12" O.D. are indicated.

Based on standard air at .075 lb./cu.ft.

©Kice Industries, Inc. All rights reserved.



# What type of filter?

©Kice Industries, Inc. All rights reserved.

# Filter Types



©Kice Industries, Inc. All rights reserved.

# Types of Filter Inlets

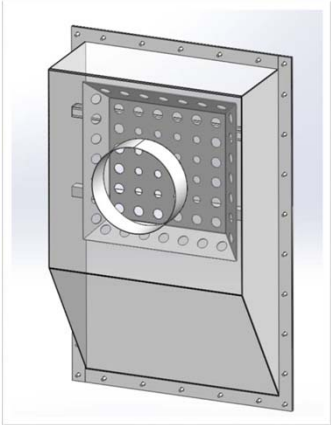

**High Air Inlet**

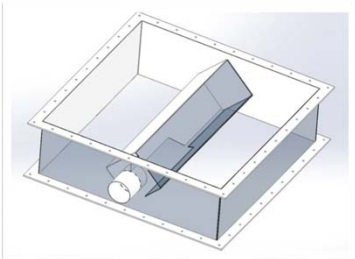

**Material Handling Inlet**

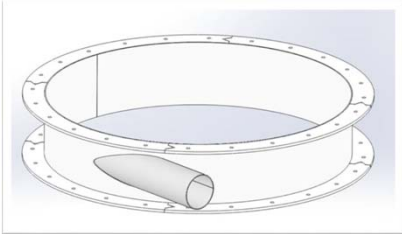

**Cyclonic Inlet**

©Kice Industries, Inc. All rights reserved.



## Bag Cleaning Systems (Venturi-Jet)

- High Pressure, Low Volume
  - 80 to 100 psig air at low volume
  - Cleaning air supplied by “house” compressed air system
  - Oil and moisture contamination from “house” compressed air system are common



©Kice Industries, Inc. All rights reserved.



## Bag Cleaning Systems (Pneu-Jet)

- Medium Pressure
  - 9-12 psig at moderate to high air volume
  - Use of positive displacement blower to supply air
  - Air supply is local to inlet of PD blower; oil and moisture contamination not typically a problem



©Kice Industries, Inc. All rights reserved.



## Bag Cleaning Systems (Reverse-Air) "Kice CR"

- Low Pressure
  - 20-30" w.c.
  - Use of fan to deliver high volume of air at low pressure

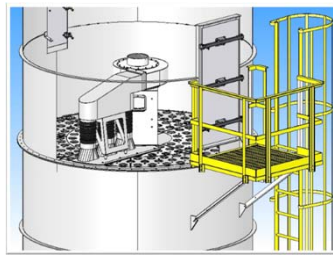

©Kice Industries, Inc. All rights reserved.



## Air-to-Cloth Ratio & Can Velocity

©Kice Industries, Inc. All rights reserved.



## Air-to-Cloth Ratio

- Establishes design capacity of a baghouse
- Term refers to ratio of air quantity (cubic feet per minute or CFM) to the amount of media surface area within filter (square ft.)
- $\text{Air Volume (CFM)} \div \text{Cloth Area (SQ.FT.)} = \text{Air to Cloth Ratio}$
- Example:  $15,000 \text{ CFM} \div 1,555 \text{ sq ft} = 9.65:1 \text{ Air to Cloth Ratio}$

©Kice Industries, Inc. All rights reserved.



## Rule of Thumb for designing Air-to-Cloth Ratio

- 7-10:1 Ratio: Elevator, Cleaning House, General Suction
- 7:1 Ratio: Secondary Collector, High Humidity Air Systems
- 5:1 Ratio: Filter/Receiver, Centro-Vacs



©Kice Industries, Inc. All rights reserved.



## Can-Velocity of a Baghouse

- Can Velocity is measured in feet per minute (FPM).
- Determined by dividing the total air flow entering the baghouse chamber by the cross sectional area of the filter housing (less bag area)

Example:

$$15,000 \text{ CFM} \div (77.2 \text{ sq ft} - 20.63 \text{ sq ft}) = 265 \text{ FPM}$$

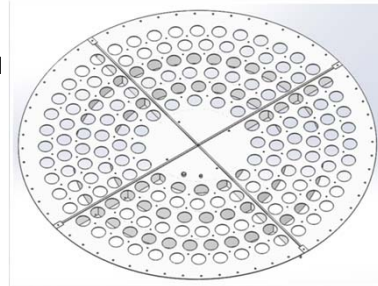

©Kice Industries, Inc. All rights reserved.



## Can-Velocity of a Baghouse

### “Rule of Thumb” for Can-Velocity

- Varies with application, but can generally assume a Can-Velocity at 300 FPM or below to be acceptable.
- Example: 5 ft. diameter housing with 19.6 sq.ft. net flow area, handling 6,000 CFM = 306 FPM Can-Velocity.

Bulk Density (lbs/cu ft)	Filter Can Velocity (fpm)
30-50	300-360
<30	300
<20	180-240
<10	120-180
<5	60-120
<1	<60

©Kice Industries, Inc. All rights reserved.



## What type of filter bags?

©Kice Industries, Inc. All rights reserved.



### Baghouse Filter Operation

- Utilizes fabric socks/media
- Very efficient; from 99.8% on 10 micron particles utilizing 16 oz. polyester felt bags, up to 99.9% on sub-micron size particles utilizing special finish bags
- Filter bags and “dust cake” on surface of media act to separate particles from incoming dirty airstream, resulting in clean air exiting baghouse to atmosphere

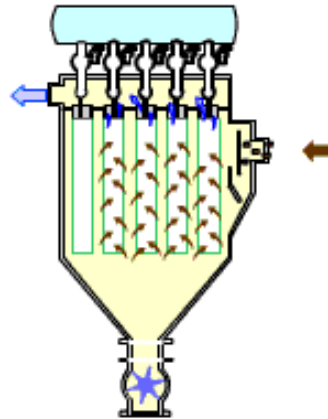

©Kice Industries, Inc. All rights reserved.



## Filter Bag Media

- Selection of proper media plays a major role in filter performance.
- Must consider several factors of application:
  - *Operating temperatures*
  - *Humidity and moisture levels*
  - *Type of particulate being handled*
  - *Resistance to abrasion, chemicals, moisture, etc.*
  - *Air-to-Cloth Ratio*

©Kice Industries, Inc. All rights reserved.



## Filter Bag Media

- Most common media in our industry is 16 oz. singed felted polyester or 10.5 oz. Dura-Life bags (Kice Standard).
  - *Function using "Depth Filtration" where a "dust cake" build-up on surface of media filters particulate from airstream.*
  - *Limited by A/C ratio of baghouse.*
    - High A/C ratio causes decreased bag life and increases pressure drop across filter bags.
    - High moisture and temperatures may also limit the use of polyester bags.

©Kice Industries, Inc. All rights reserved.



## Filter Bag Media

- Trends include the Cartridge Filters.
- Consists of media in pleated form (25-35 pleats most common).
- Can be provided in a variety of media.
- Provides more media surface area per filter (up to 3 times more vs. standard bag).
- Requires low air to cloth ratios.



- Polyester
- Polypropylene
- Aramid
- Acrylic
- Fiberglass
- P84™
- PTFE
- PPS

©Kice Industries, Inc. All rights reserved.



# What type of fans?

©Kice Industries, Inc. All rights reserved.



## TYPES OF CENTRIFUGAL FANS

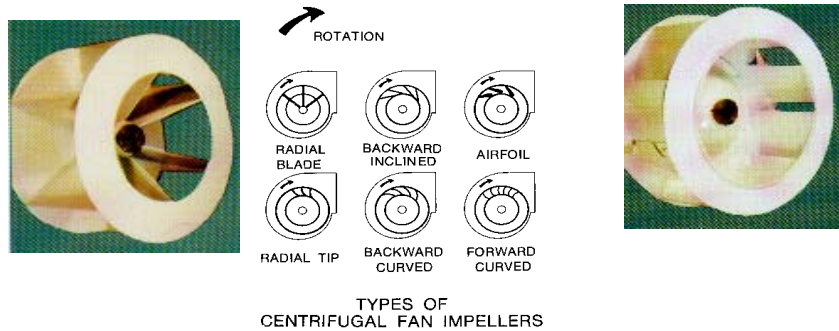

©Kice Industries, Inc. All rights reserved.



## “FC” Series Centrifugal Fans

- Flat Radial Blade
  - *Static efficiency 55-68%*
  - *Features: Reversible; self-cleaning; less efficient than airfoil blade; changes in static pressure can cause motor to overload*



©Kice Industries, Inc. All rights reserved.



## “FC” Series Fan Applications

- Material handling – product or dust in air stream
- High static pressure
- Pneumatic conveying (mill lifts, etc.)
- General suction



©Kice Industries, Inc. All rights reserved.



## “FA” Series Centrifugal Fans

- Backwardly Inclined Airfoil Blade
  - *Static efficiency 70-80%*
  - *Features: Non-overloading; airfoil shaped blade cross section results in high efficiency, but is susceptible to material buildup; non-reversible*



©Kice Industries, Inc. All rights reserved.



## “FA” Series Fan Applications

- Clean air stream
- High air volume
- Low to medium static pressure
- Dust control systems
- General ventilation
- Filter exhaust



©Kice Industries, Inc. All rights reserved.



## Dust System Troubleshooting

©Kice Industries, Inc. All rights reserved.



## Capacity Problems – High Air-to-Cloth Ratio Symptoms

- Premature increase in pressure drop as dust migrates into bags.
- Reduced air flow in dust collection system - dusting out at pickup points in system
- Stack emissions
- Short bag life



## Capacity Problems – High Air-to-Cloth Ratio Symptoms

- Additional ducts tied into baghouse filter over time increasing air volume to the filter
  - *Add an additional Baghouse filter to system to lower the Air-to-Cloth ratio of each filter.*
  - *Reallocate some of the system to another existing baghouse filter, after first confirming it has adequate capacity.*
  - *Replace bags with those made from higher quality media utilizing “surface filtration”, or try pleated cartridge filters.*



## Capacity Problems – High Air-to-Cloth Ratio Solutions

- Confirm actual air volume handled by filter matches design.
  - Fans are often oversized so that they can be dampered back for future additions, or increased as pressure drop rises naturally.
  - Fan damper may be wide open allowing too much air to the filter, increasing Air-to-Cloth ratio.
    - Damper fan back to reduce air volume.
  - Fan may not have damper and is pulling more air to filter than designed for.
    - Add a damper and adjust to proper air volume.



## Bag Cleaning System Problem Symptoms

- If pressure, frequency, amplitude settings are too high - may result in over cleaning of bags:
  - Causing premature bag failure in the form of rips in seams or holes allowing stack emissions.
  - May prevent “dust cake” build up on bags utilizing “depth” filtration, resulting in:
    - Particles allowed to “bleed-through” bags, producing emissions to atmosphere.
    - Bags blinded over by small particulate imbedding in bags without “dust cake” – resulting in increased pressure drop, reduced air volume, and shortened bag life.
  - Waste of Energy!



## Bag Cleaning System Problems Solutions:

- Confirm actual settings.
- Adjust Timer Board to correct settings for your application:
  - *Pressure adjustment on timer board*
    - “Time off” setting can increase/decrease pressure of air during each pulse to bags.
  - *Duration adjustment on timer board*
    - “Time on” setting can increase/decrease time valve stays open to control duration of air to bags.

What is normal?  
“On” setting default:  
“Off” setting default:

©Kice Industries, Inc. All rights reserved.



## Bag Cleaning System Problems Solutions:

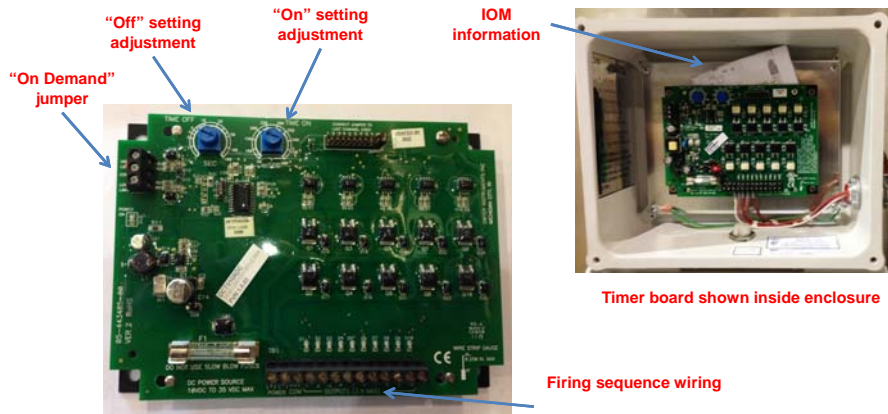

©Kice Industries, Inc. All rights reserved.



## Suction Problems – “Somebody changed something”

- Hoods and/or equipment is dust out
- Picking up good product
- Lack of “suction” or Too much “suction”
  - *Somebody changed something!*
    - Closed a damper or opened a damper.
    - Blocked or added a connection
  - *When a connection is changed, it changes suction (for good or bad) everywhere.*
    - Once balanced, either measure and/or mark dampers as a reference point if it gets out of balance.

©Kice Industries, Inc. All rights reserved.



## Bag Media Problems

- Dusting out or Stack emissions to atmosphere.
  - *Bags installed wrong*
  - *Worn bag(s) with holes or tears.*
  - *Bag(s) missing that were not installed or have fallen from tube sheet connection.*
  - *Bags may be OK, but tube sheet is worn or damaged and has crack(s), hole(s), etc...*

Wrong way



Right way



©Kice Industries, Inc. All rights reserved.



## Filter does not empty properly

- Worn airlock causing too much air loss.
  - Does not allow the vanes to fill with dust.
  - Dust is hanging up and not dropping.
  - Can feel a slight negative pressure (suction) under airlock
- Hopper angle too shallow for the sticky dust.
- Hopper outlet too small.
- Stopping airlock when filter is shut down
  - Material drops off, goes into hopper and cannot get out
  - Material can then bridge over
  - Run airlock 5 minutes after fan and/or filter is shut down

©Kice Industries, Inc. All rights reserved.



## Fan Issues

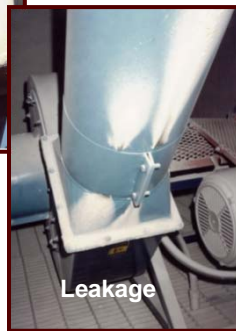
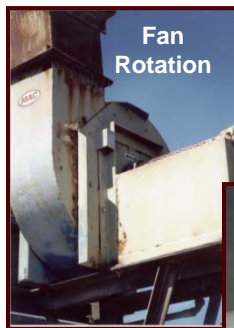

©Kice Industries, Inc. All rights reserved.



## Dust System Maintenance

- Filter Bag changing when differential pressure is too high.
- Routine checking/changing of solenoids, diaphragms, springs.
- Duct cleaning if buildup due to condensation.
- Airlock bearings, seals, and check clearances.
- Fan bearing lubrication, check sheaves, belts, vibration monitoring.
- Bag Cleaning Air Power Unit inlet filter check, lubrication, check sheaves, belts, relief valve.



## Explosion Protection



## Applicable NFPA Standards

- **NFPA 61** – *Standard for the Prevention of Fires and Dust Explosions in Agricultural and Food Processing Facilities*
- **NFPA 68** – *Standard on Explosion Protection by Deflagration Venting*
- **NFPA 69** – *Standard on Explosion Prevention Systems*
- **NFPA 77** – *Recommended Practice on Static Electricity*
- **NFPA 654** - *Standard for the Prevention of Fire and Dust Explosions from the Manufacturing, Processing, and Handling of Combustible Particulate Solids*

©Kice Industries, Inc. All rights reserved.



## NFPA 68

### Definitions:

**P<sub>max</sub>** (Maximum Pressure) – “The maximum pressure developed in a contained deflagration of an optimum mixture.”

- a function of the material being combusted
- “determined in approximately spherical calibrated test vessels of at least 20 L capacity...”

**K<sub>st</sub>** – “The deflagration index of a dust cloud.”

- *K<sub>st</sub> “shall be computed from the maximum rate of pressure rise attained by combustion in a closed...approximately spherical calibrated test vessel of at least 20 L capacity...”*
- *Published lists of example values are available for certain materials, but variations in characteristics, such as particle size and moisture content, of seemingly identical materials can produce varied results.*

**NOTE:** *NFPA 68 states “where the actual material is available, the K<sub>st</sub> shall be verified by test.”*

©Kice Industries, Inc. All rights reserved.



## Explosion Protection Considerations

- Is the filter located inside or outside? If inside how close to outside wall?
- Is the fan on the dirty side of the filter? Spark detection, prevention?
- Calculation of the filter specifications, Kst, and Pmax determine the explosion vent size. Length of duct to outside wall also affects vent size.
- Is suppression the best alternative? Cost, maintenance?
- Is isolation needed?

©Kice Industries, Inc. All rights reserved.



## NFPA Compliant Outboard Bearing Airlocks

- By using an Kice Airlock with our outboard bearing design, standard clearances, and metal tips we meet NFPA 69 standard as an isolation device (for the bottom of the filter)

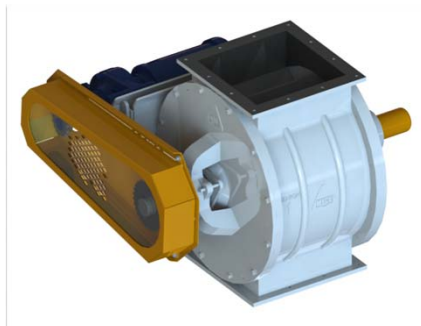
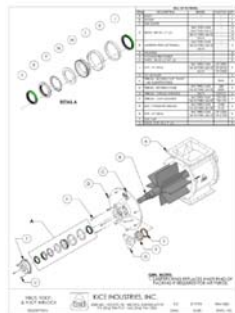

©Kice Industries, Inc. All rights reserved.



## MAINTAINING THE SOLUTION

### To Review:

- Locate the source of dust
- Close up sources of dust where you can
- Chose proper hood design for the application
- Apply the correct air and velocity
- Taper the ducting size back to the cyclone or filter as the air volume increases
- Decide on a cyclone or a baghouse filter system

### After Installation:

- Balance the system (set the dampers) and then leave alone
  - **Opening a damper "here" only hurts you over "there" ....**
- Maintain the equipment – bag changes, fan bearings, ducts, etc...  
Learn to "measure the air" to make adjustments

### Allow for the future:

- If possible, add a free air inlet today to handle additional CFM for equipment that may be installed down the road.
- Re-speed the fan
- Move capped off line to another pick up point

©Kice Industries, Inc. All rights reserved.



Thank you for the opportunity to  
speak with you today



[www.kice.com](http://www.kice.com)

©Kice Industries, Inc. All rights reserved.