



Leader in flour applications.

# Improvement of Pasta and Noodle Flour

**Hendrik Moegenburg**  
**Mühlenchemie GmbH & Co. KG**  
**Ahrensburg, Germany**

Mühlenchemie is a member  
of the Stern-Wywiol Gruppe



## Agenda

- ◆ Mühlchemie: the company
- ◆ Pasta and noodles
- ◆ Why focus on pasta? Challenges in pasta flour improvement
- ◆ What quality aspects can we target?
- ◆ Enzymatic pasta flour improvement
- ◆ Reduction of oil uptake in instant noodles
- ◆ Composite flour noodles

## Mühlenchemie: the company

**We have been providing customized solutions and consultancy to the milling industry for 90 years.**

**Year of establishment: 1923**

**Registered offices: Ahrensburg / Hamburg**

**Ownership: Stern-Wywiol Gruppe, Hamburg**

**Specialization:**

- Flour improvers
- Enzymes
- Vitamin and mineral premixes
- Technical services

**Market position: International market leader**

**Turnover: 65 mill. USD**

**Number of employees: 120**

**Exports: > 110 countries**





# Pasta & Noodle Production & Consumption globally

# Global Annual Production of Dried Pasta. Ten Largest Producers, 2010 (1,000 t)

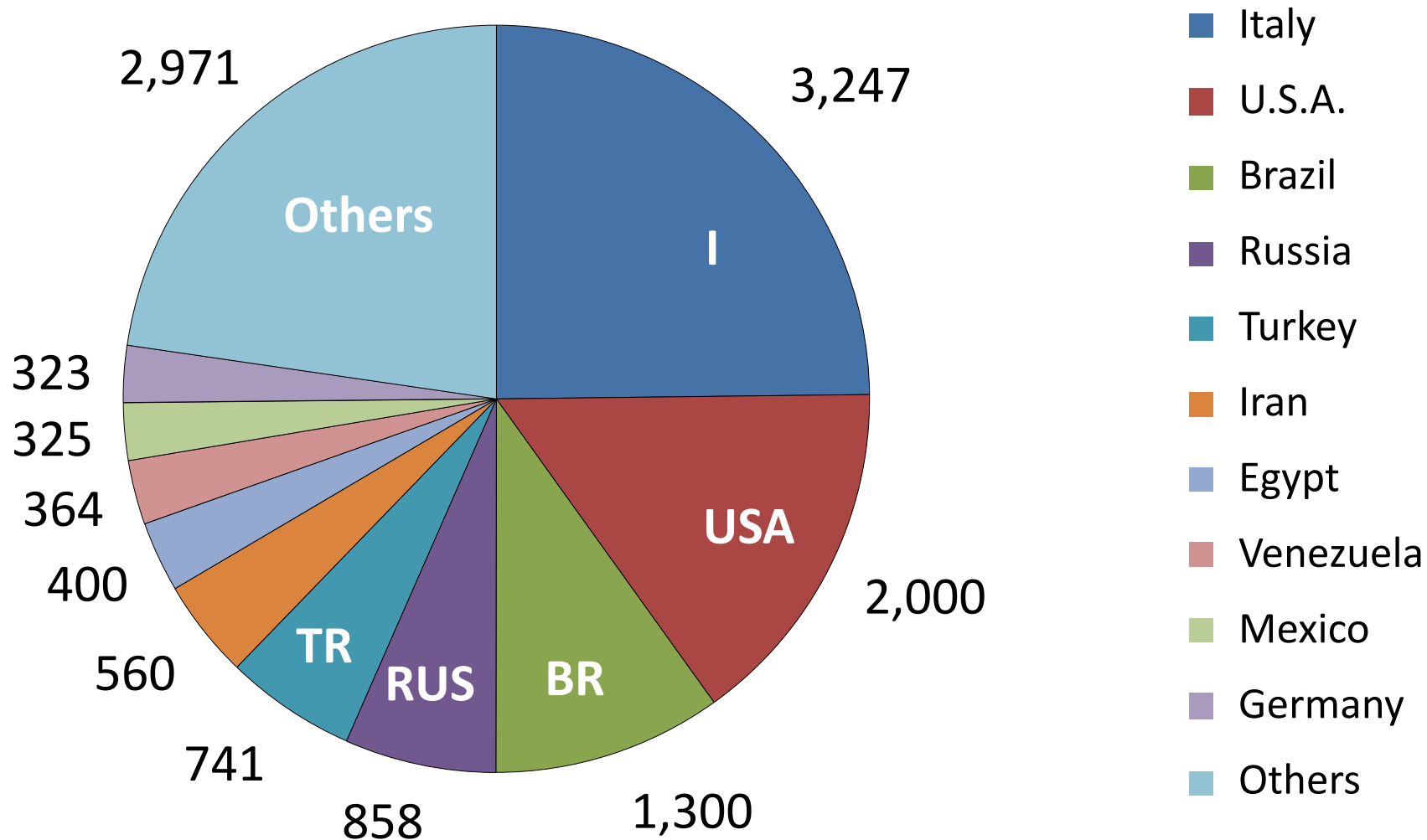

Total: 13,100

Modif. from UN.A.F.P.A.. Oct. 2011

# Global Annual Consumption of Instant Noodles. Ten Biggest Markets, 2011 (1,000 t)

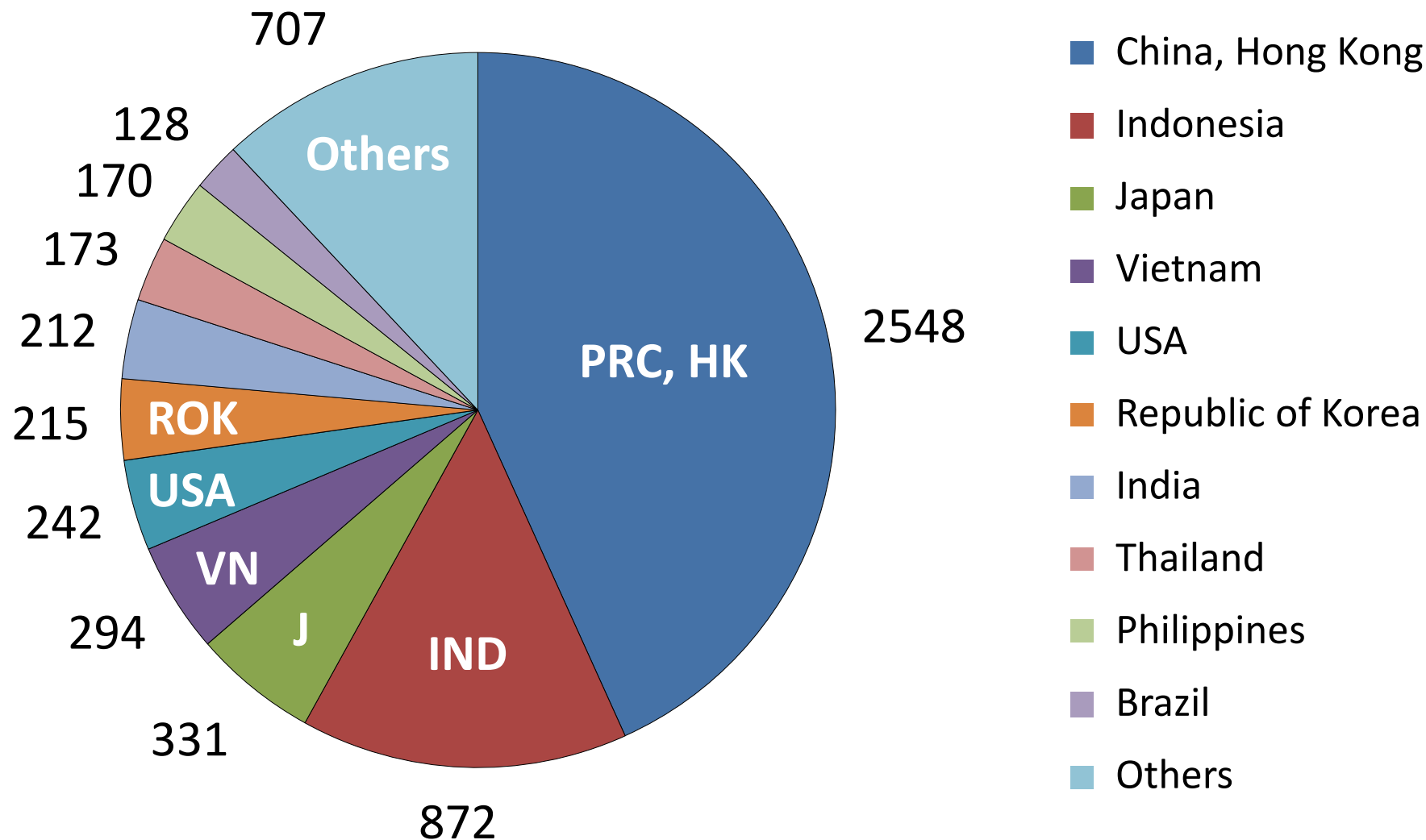

Total: 5,892

Modif. from WINA Dec. 2012



# Why focus on pasta?



## Pasta in Asia

- ◆ **Production and consumption of pasta in SEA (and also China) are still low, but on the increase**
- ◆ **.. but hardly any durum is being milled in the region**
- ◆ **.. which often leaves pasta producers with flour not ideally suited for the purpose**
- ◆ **.. and translates into an increasing number of requests for technical assistance from across the region to bridge perceived quality gaps**
- ◆ **.. while consumers, although often not accustomed to pasta (in an Italian sense), become more affluent, cosmopolitan and discerning while competition among suppliers will only increase.**

# Pasta and Mühlenchemie

- ◆ Enzymatic improvement of pasta and also noodles is challenging due to low water activity and lack of dough rest / fermentation



# Pasta Manufacturing Process

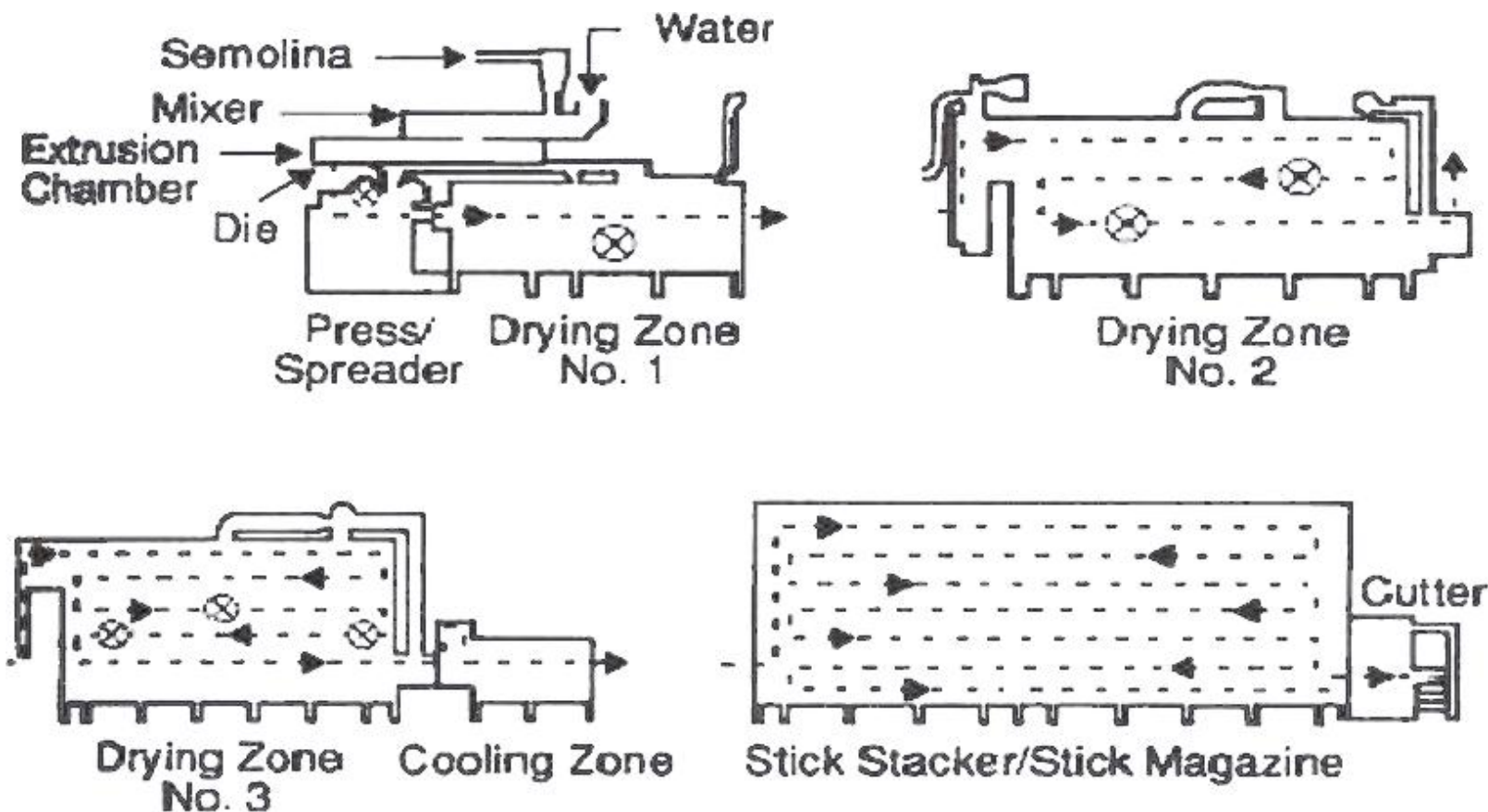

James E. Kruger, Robert B. Matsuo and Joel W. Dick, 1996.  
"Pasta and Noodle Technology"

# Noodle-Making Process

wheat → milling → flour → water, ingredients → mixing

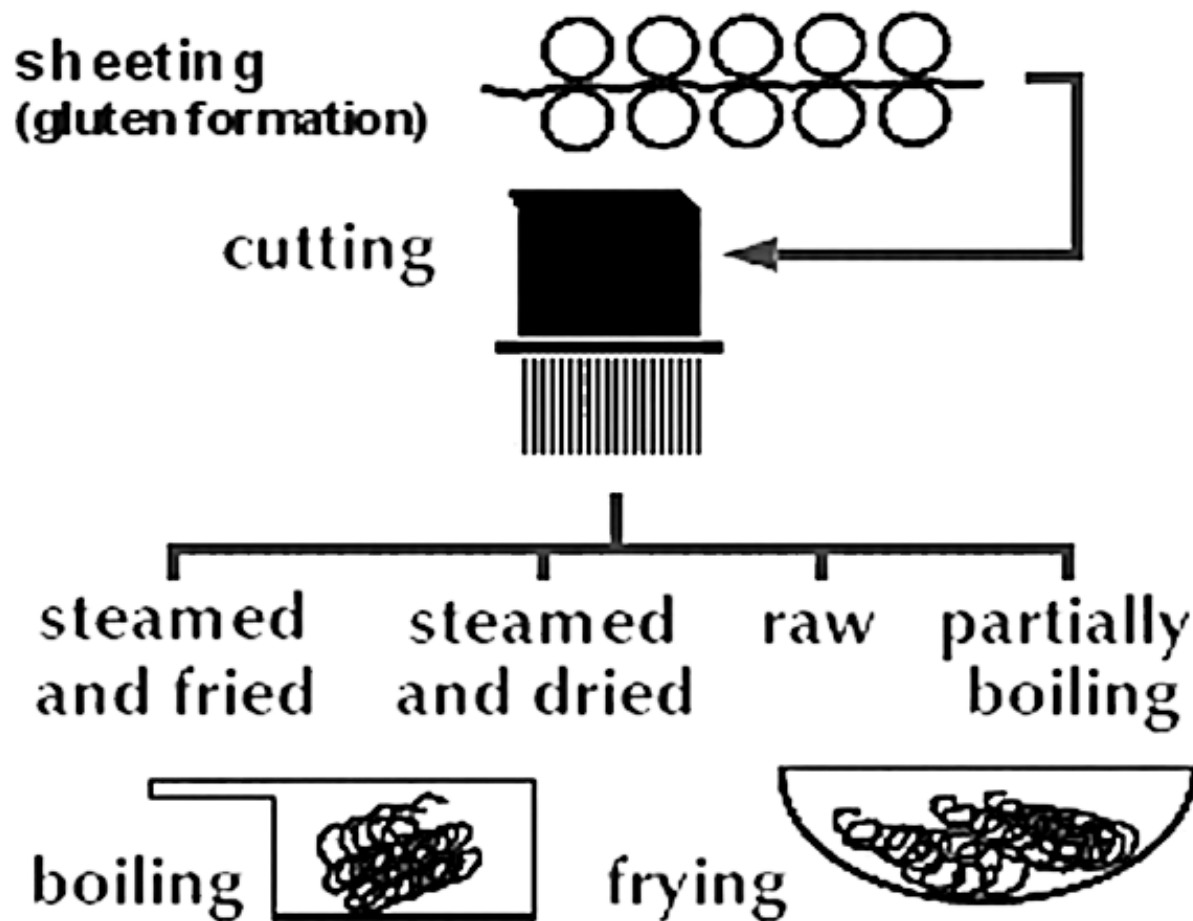

# Pasta and Mühlchemie

- ◆ **But it is technically possible to use flour additives for improving pasta flour, and formerly prohibitive costs are becoming less of an issue**

**As a side effect..**

- ◆ **many (though not all) solutions workable for pasta also yield benefits when adopted in Asian noodle making**



**What quality aspects can we target?**

# Desirable Properties for Noodle Flour and Suitable Improvers

## Properties

- ◆ **Easy processing**
  - Soft & extensible dough required
- ◆ **Uniform & quick drying**
  - Low water absorption
- ◆ **Tolerance towards moisture from fillings**
  - Firm and closed (uniform) dough structure
- ◆ **Low leaking losses upon cooking**
  - Firm and closed (uniform) dough structure
  - Low starch damage
- ◆ **High cooking tolerance (low "soakiness")**
  - Firm and closed (uniform) dough structure
  - Low starch damage
  - Good protein quality

## Improvers

- ◆ **Enzymes; softening agents**
  - Hemicellulases; cysteine
- ◆ **Enzymes**
  - Hemicellulases
- ◆ **Emulsifiers; hydrocolloids**
  - Monoglycerides; guar gum
- ◆ **Enzymes; vital wheat gluten**
  - Carboxyl esterase; transglutaminase
- ◆ **Enzymes; vital wheat gluten**
  - Carboxyl esterase; transglutaminase



# Enzymatic Pasta Flour Improvement using Carboxyl Esterases

# Action of Carboxyl Esterases

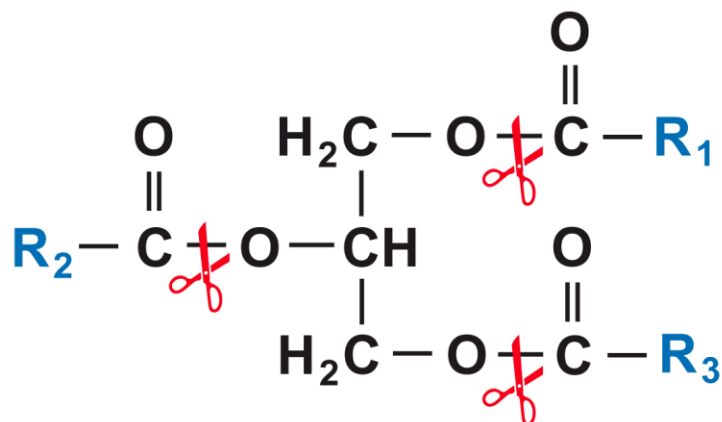

Lipases

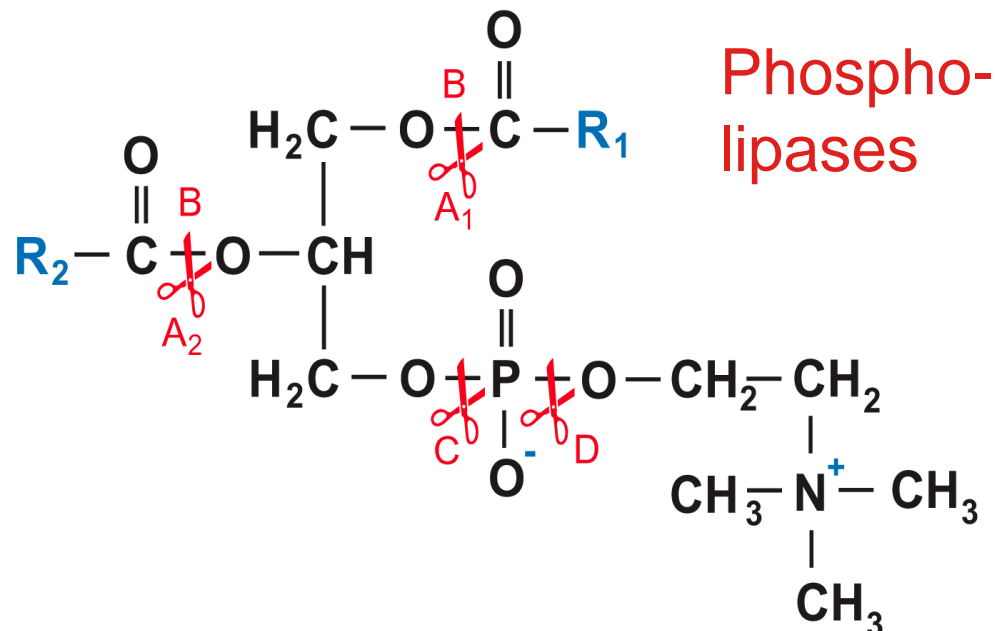

Phospho-  
lipases

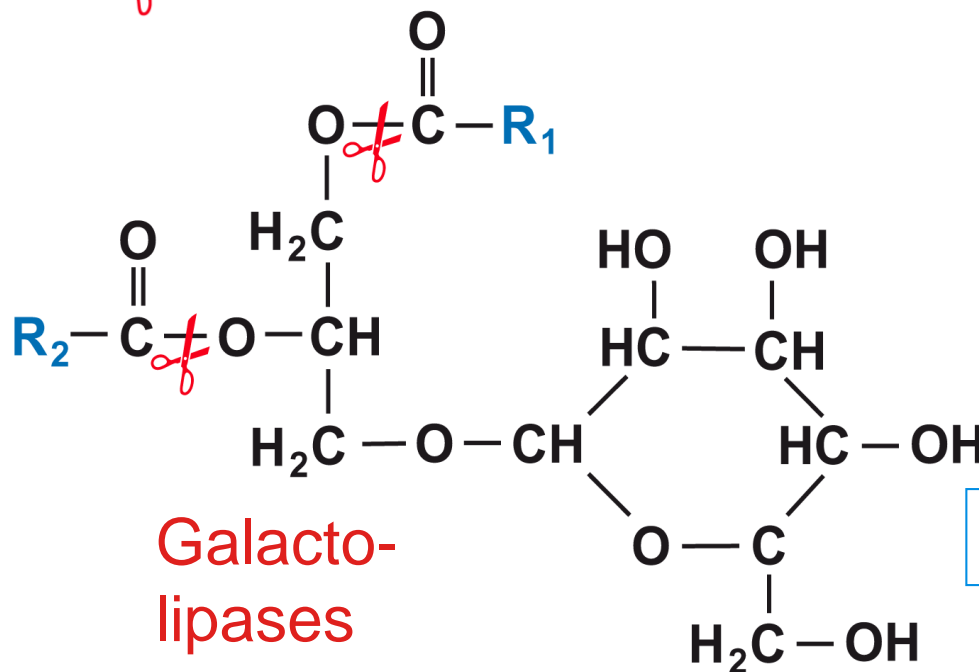

Galacto-  
lipases

$\text{R}_1, \text{R}_2, \text{R}_3 =$  fatty acid residues

# Action of Carboxyl Esterases

- ◆ Polar lipids are formed, acting as emulsifiers and interacting with the gluten
- ◆ Free unsaturated fatty acids are released, which can be converted by lipoxygenase (contained in flour naturally) ..
- ◆ ... resulting in the formation of hydroperoxides, which can act as oxidants and lead to protein strengthening and bleaching (oxidation of pigments).

# Objectives for pasta / noodle enzymes

- ◆ Making production of noodles from soft and hard wheat possible
- ◆ Improving color and brightness
- ◆ Increasing the firmness of cooked noodles
- ◆ Enhancing tolerance to overcooking
- ◆ Reducing oil uptake of fried instant noodles
- ◆ Reducing drying time of noodles
- ◆ Improving surface appearance and mechanical stability of dried noodle and pasta products
- ◆ Reducing of raw material costs.

# Texture Analyser Test

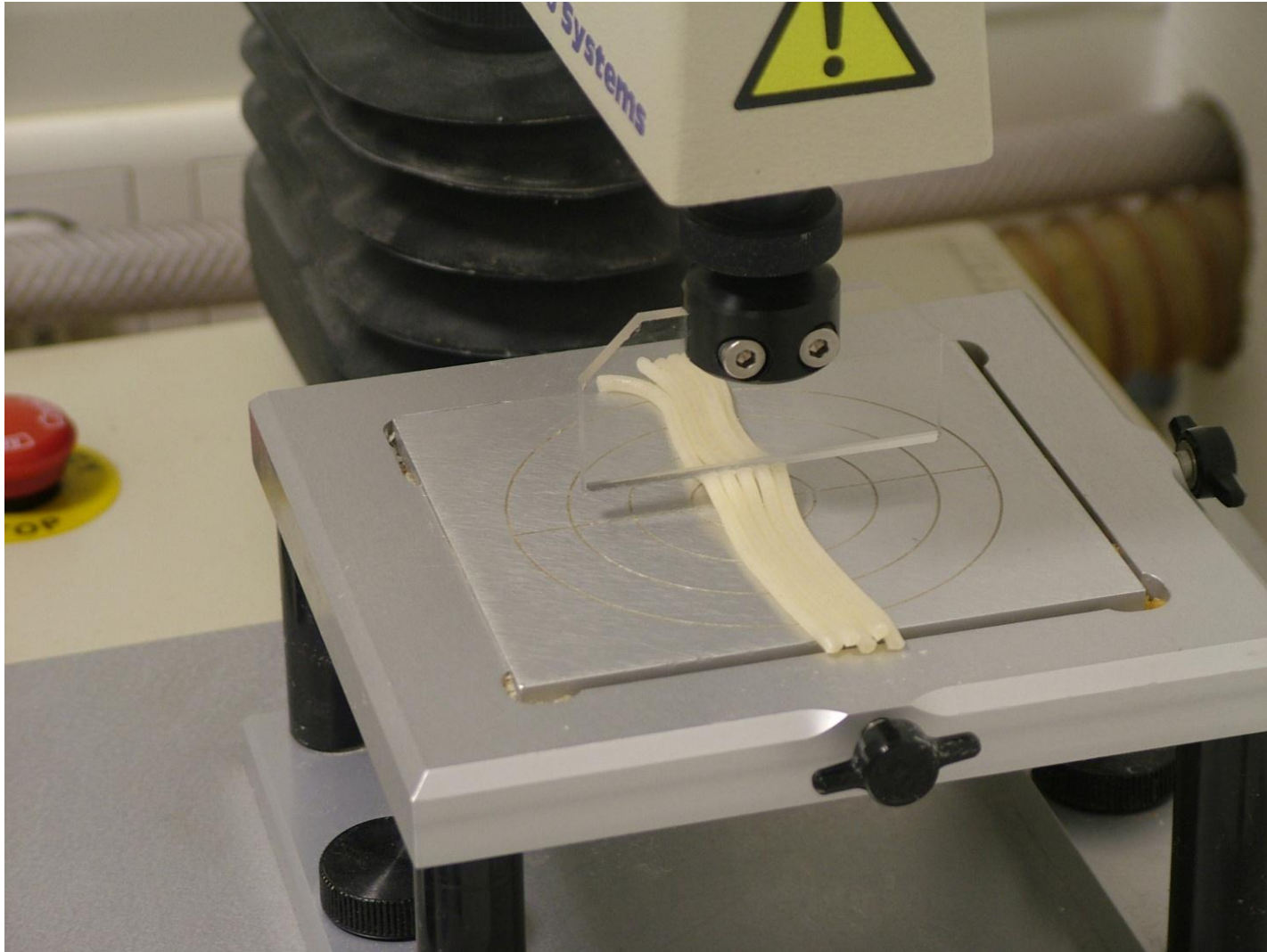

# Texture Analyser Test

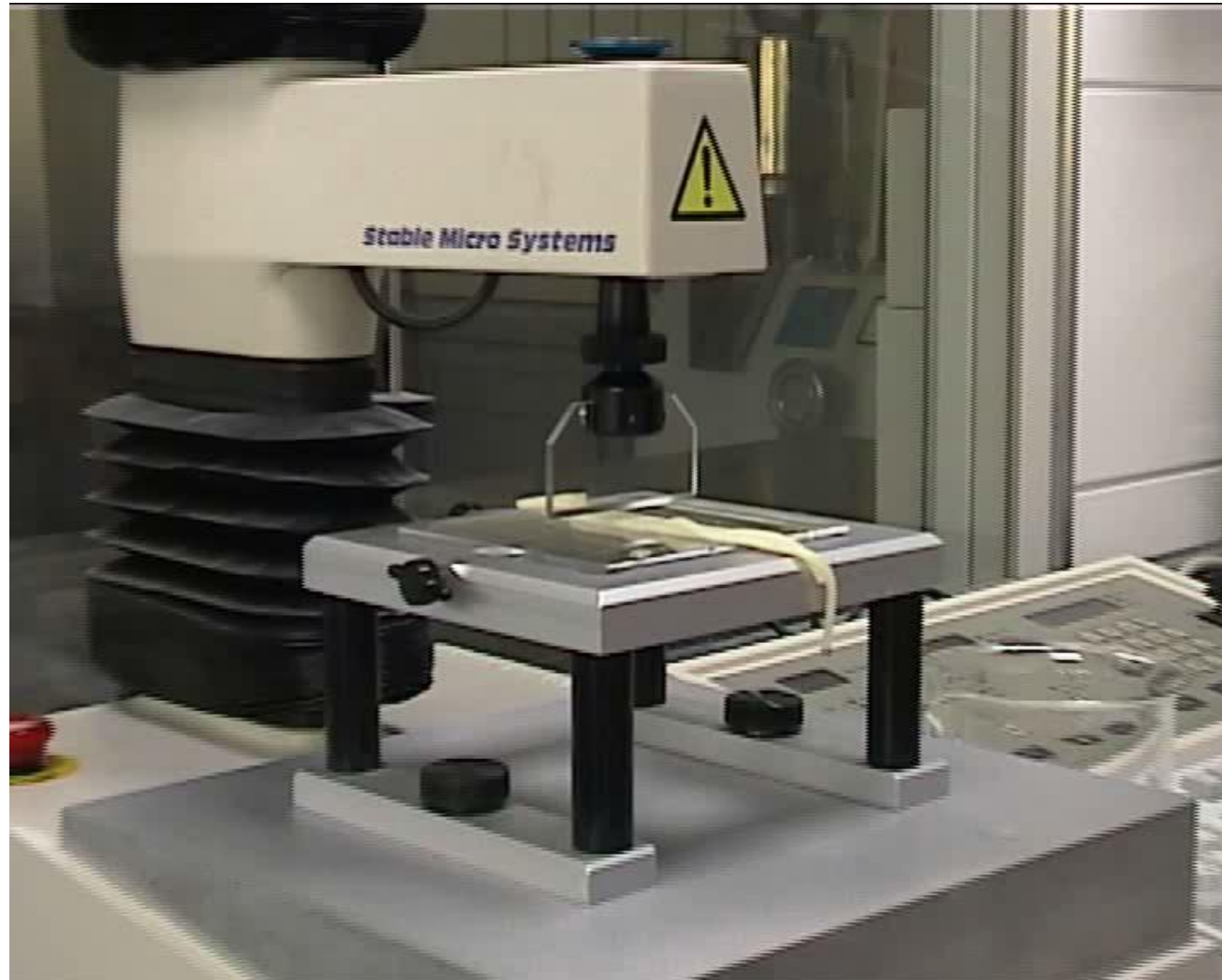

# Improvement of Over-Cooking Tolerance with Pastazym

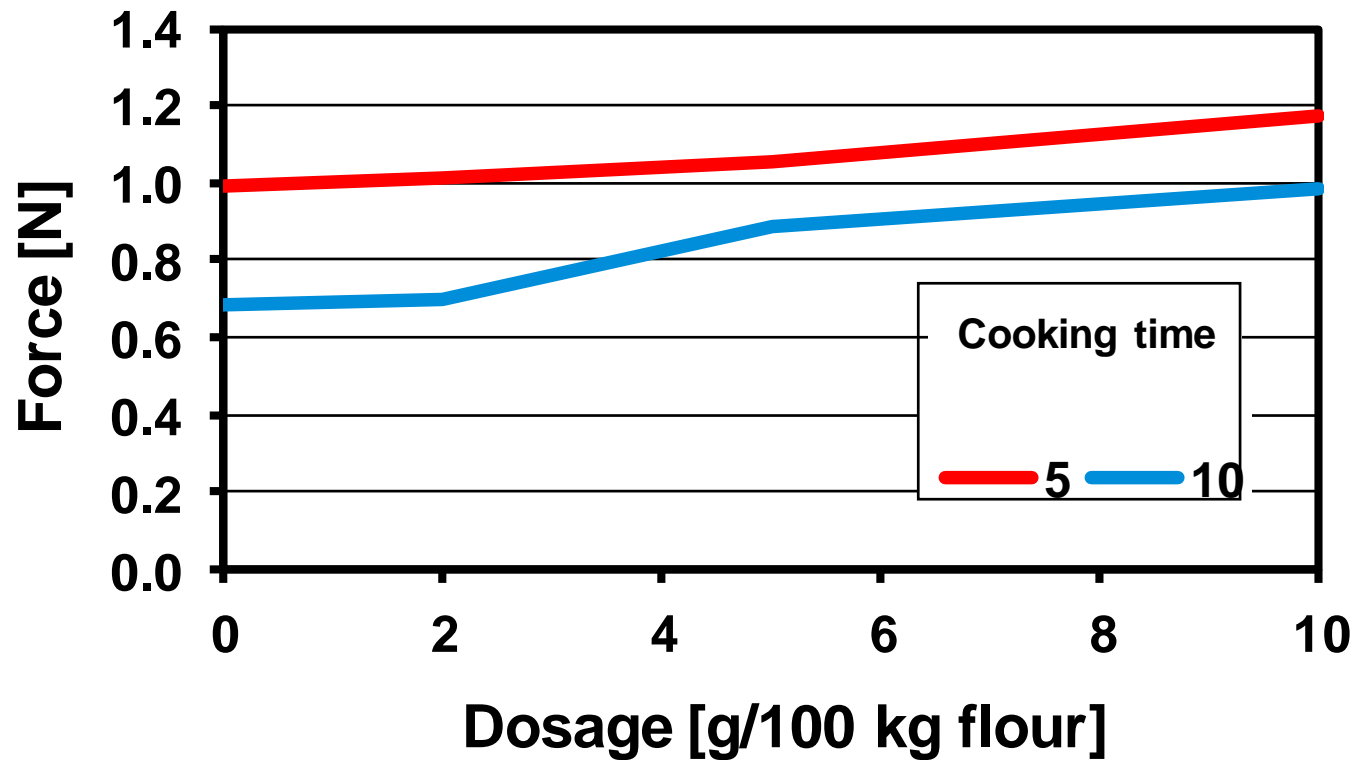

# Firmness of Cooked Instant Noodles from Soft Wheat Made with Pastazym

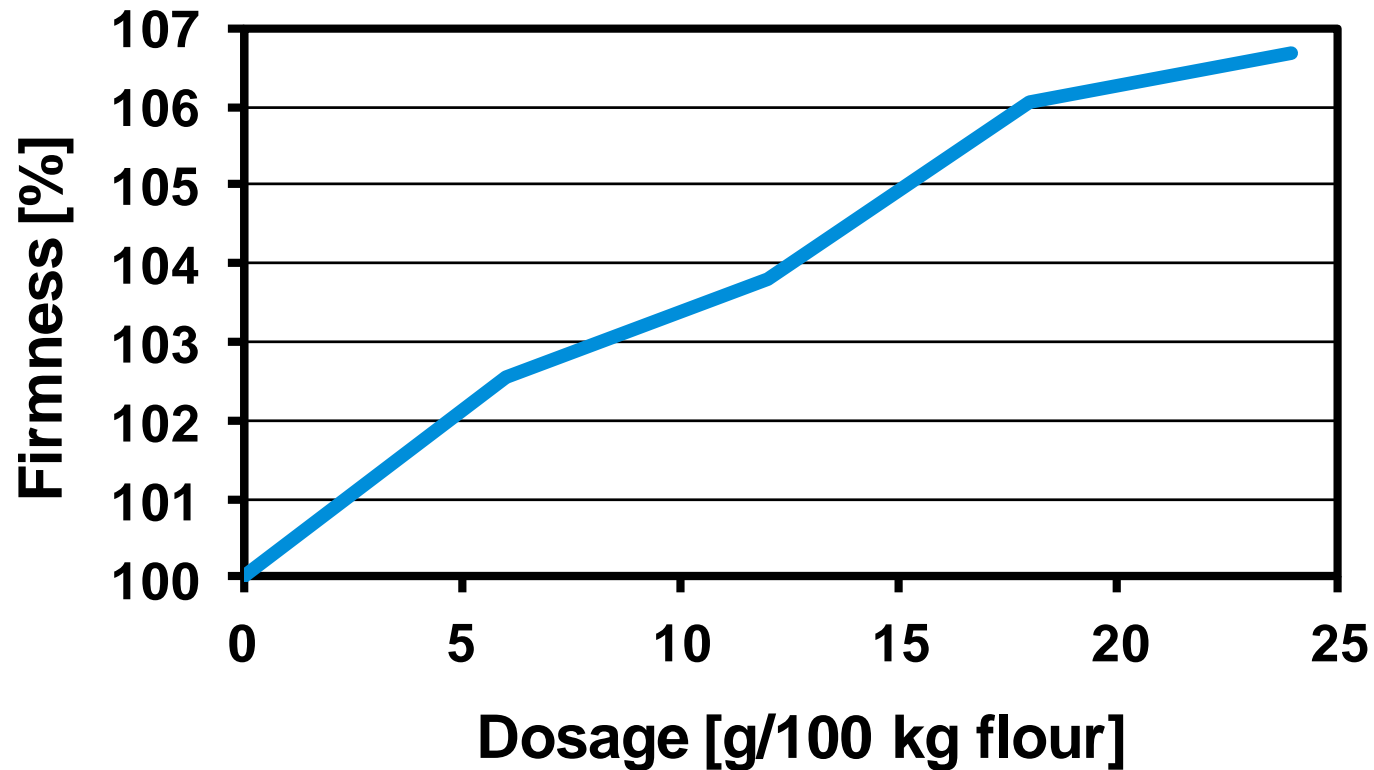

# Color of Fresh, Uncooked Noodles

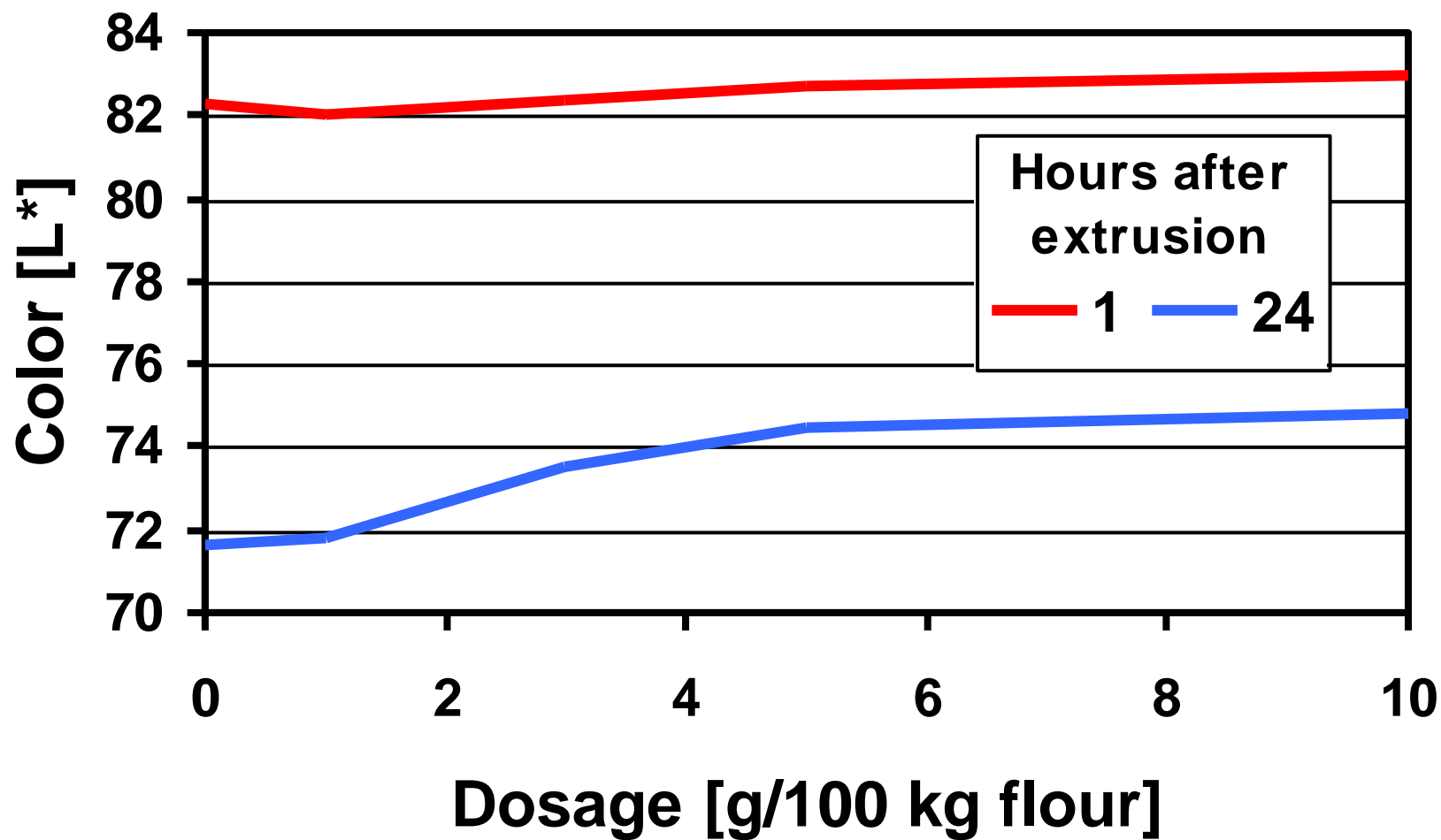

# Effect of Pastazym on the Color of Dry Noodles from Soft Wheat Flour



Reference

with Pastazym

# Effect of Colorants on Noodle Appearance



Durum wheat



Soft wheat



Pastazym, tartrazin,  $\beta$ -carotene



Pastazym, folic acid,  $\beta$ -carotene

# Durum Colour for Soft Wheat Pasta

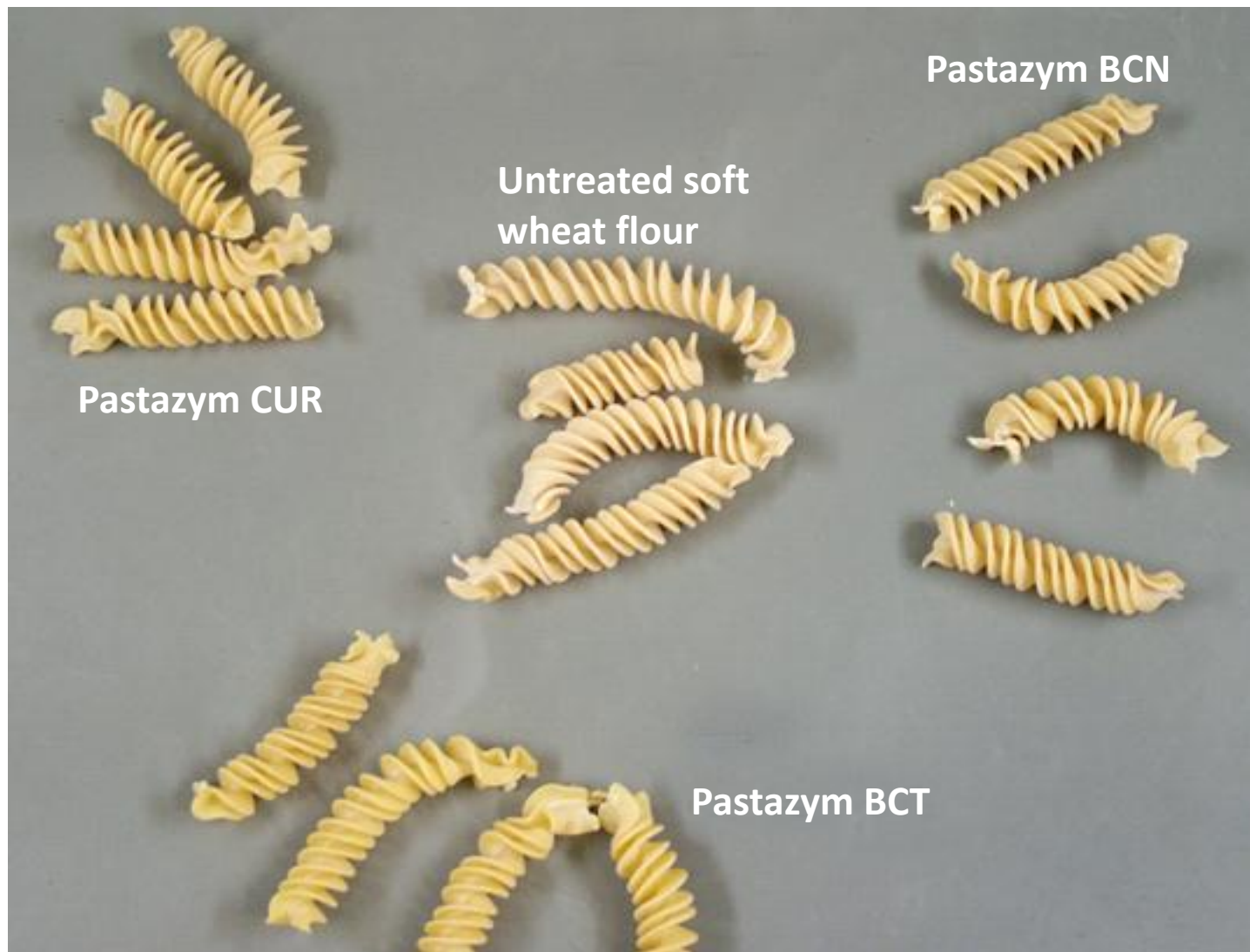

# Effect of Pastazym CUR on the Colour of Cooked Pasta from Soft Wheat Flour



**Pastazym CUR 500 ppm**

**Untreated**

→ **Pastazym CUR reduces the greyish shine of pasta made from soft wheat flour**

# Effect of Pastazym Cur, Pastazym BCN and Pastazym BCT on Firmness of Soft Wheat Noodles

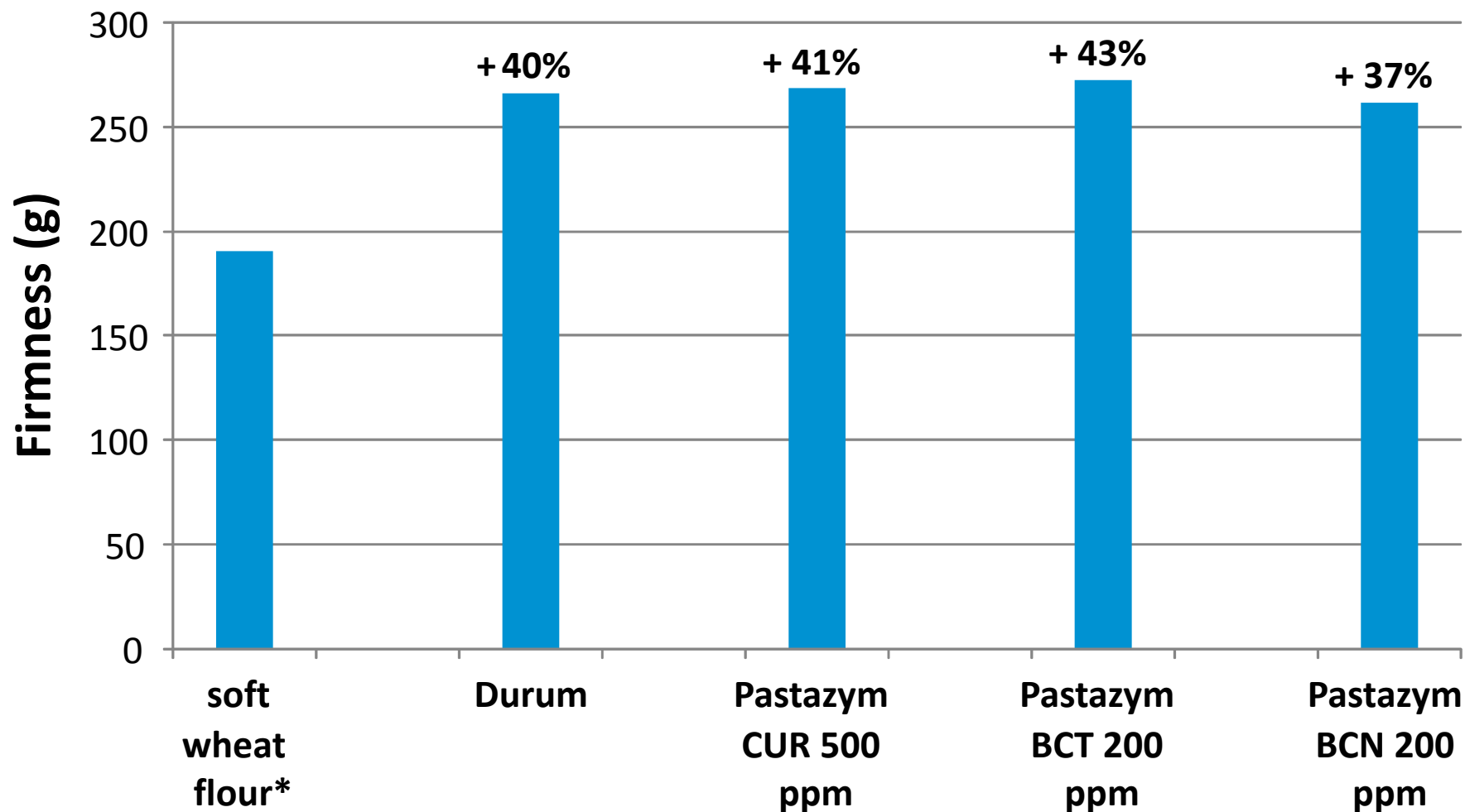

# Effect of Pastazym Plus on Stickiness of *Cooked* Spaghetti not made from durum semolina

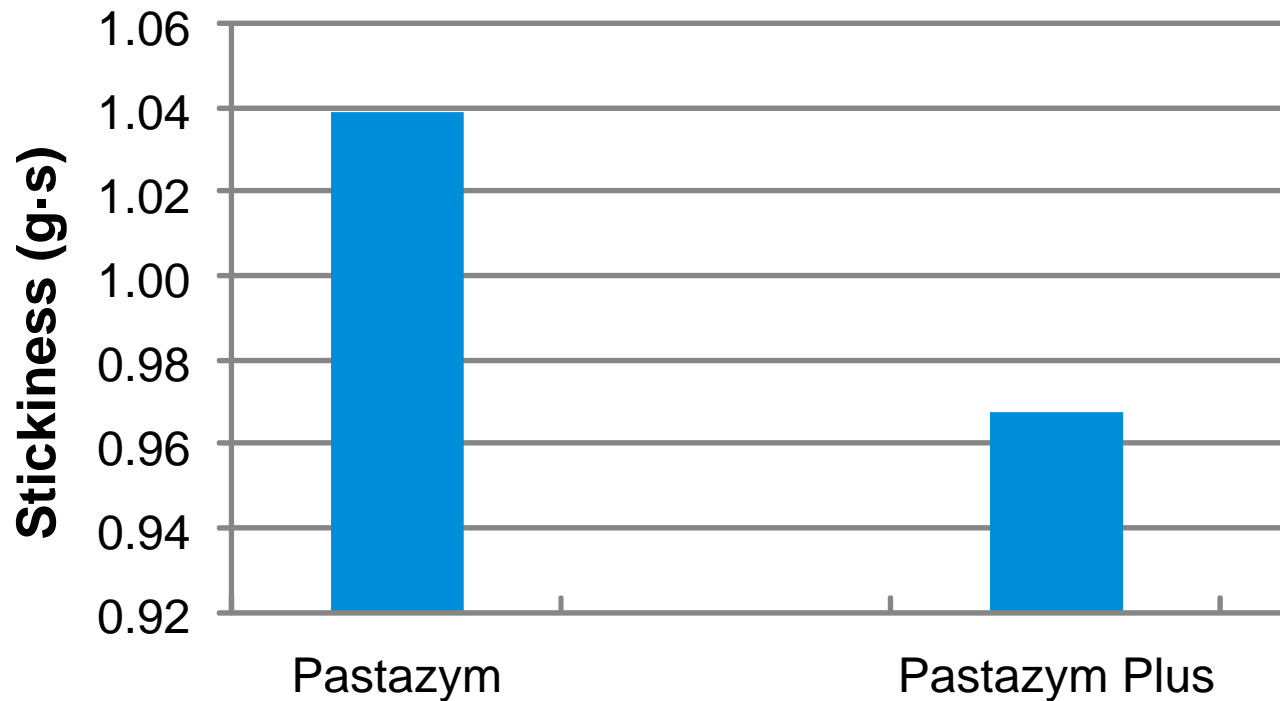

**Dosage: 200 ppm on soft wheat flour\***

\*soft wheat flour type 55; protein 12.1%; ash 0.6%; wet gluten 27.6%

# Reduction of Starch Leaching by Pastazym Plus

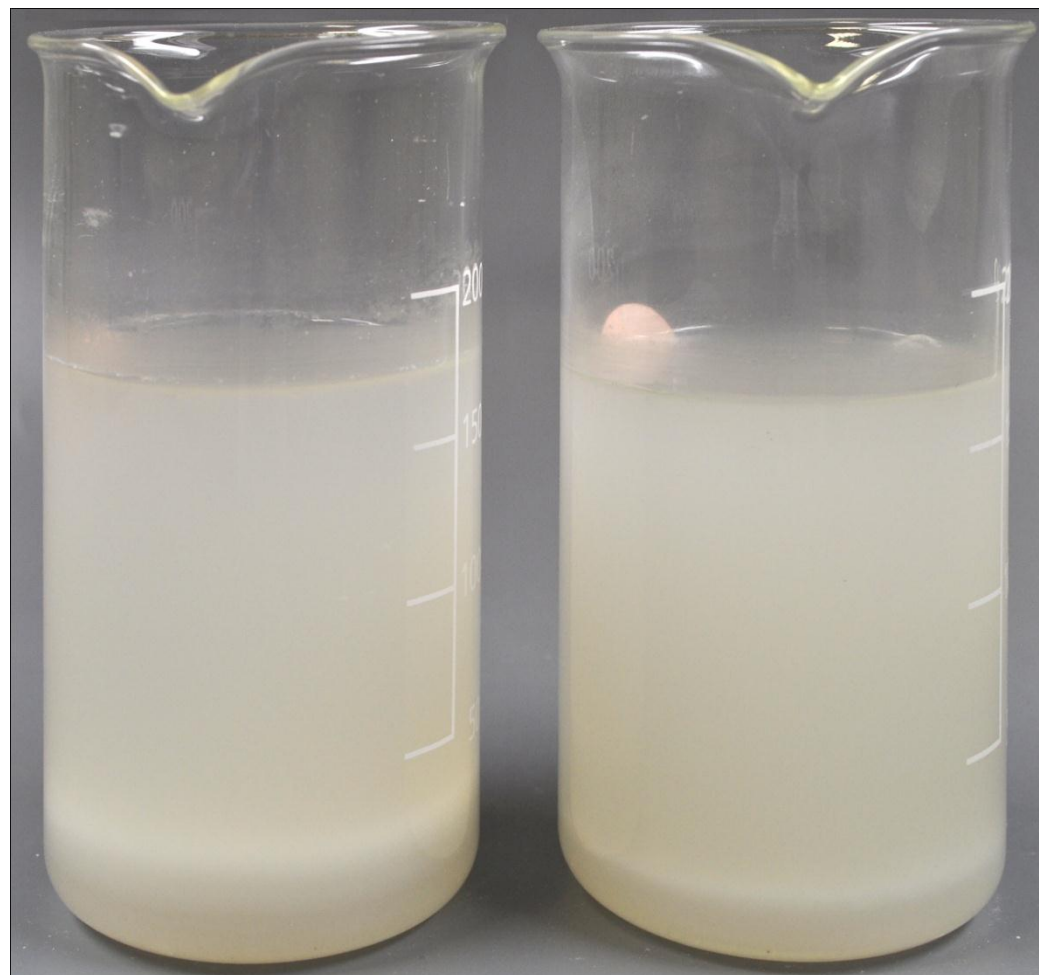

Reference

Pastazym Plus,  
200 ppm

# Cost Advantage by Pastazym Plus in Pasta

## 200 ppm Pastazym Plus

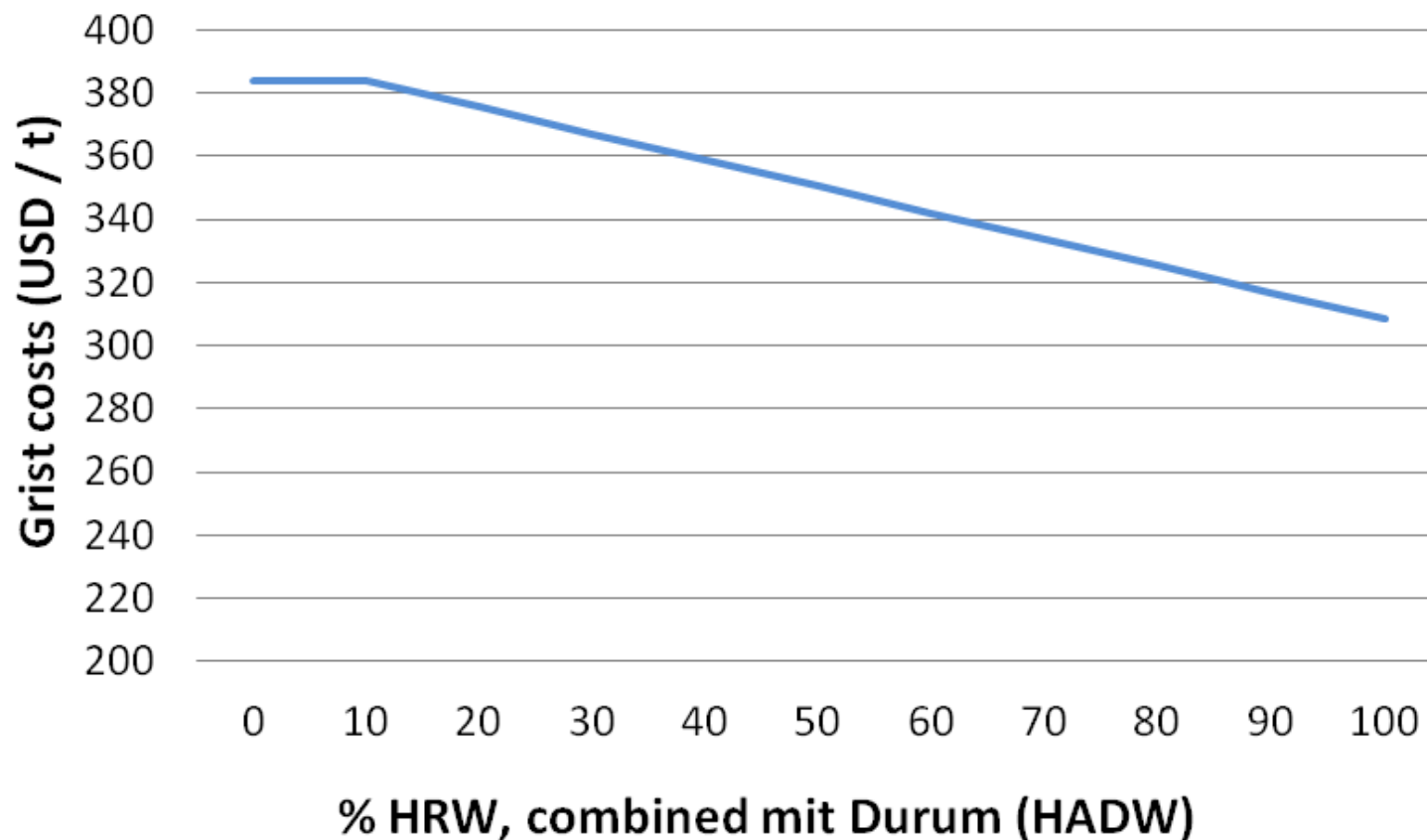

Calculation based on January 2012 figures

# Properties of the Pastazym Family

Property	Pastazym	Pastazym Plus	Pastazym BCT	Pastazym BCN	Pastazym CUR
Colour	--	-	+++	++	++
Firmness	++	++	++	++	++
Stickiness	--	---	--	--	--
Cost reduction	++	+++	++	++	+

**- = reduction**

**+ = increase**



# Reduction of Oil Uptake into Instant Noodles

# Visualization Oil Uptake into Instant Noodles by Sudan Red Staining

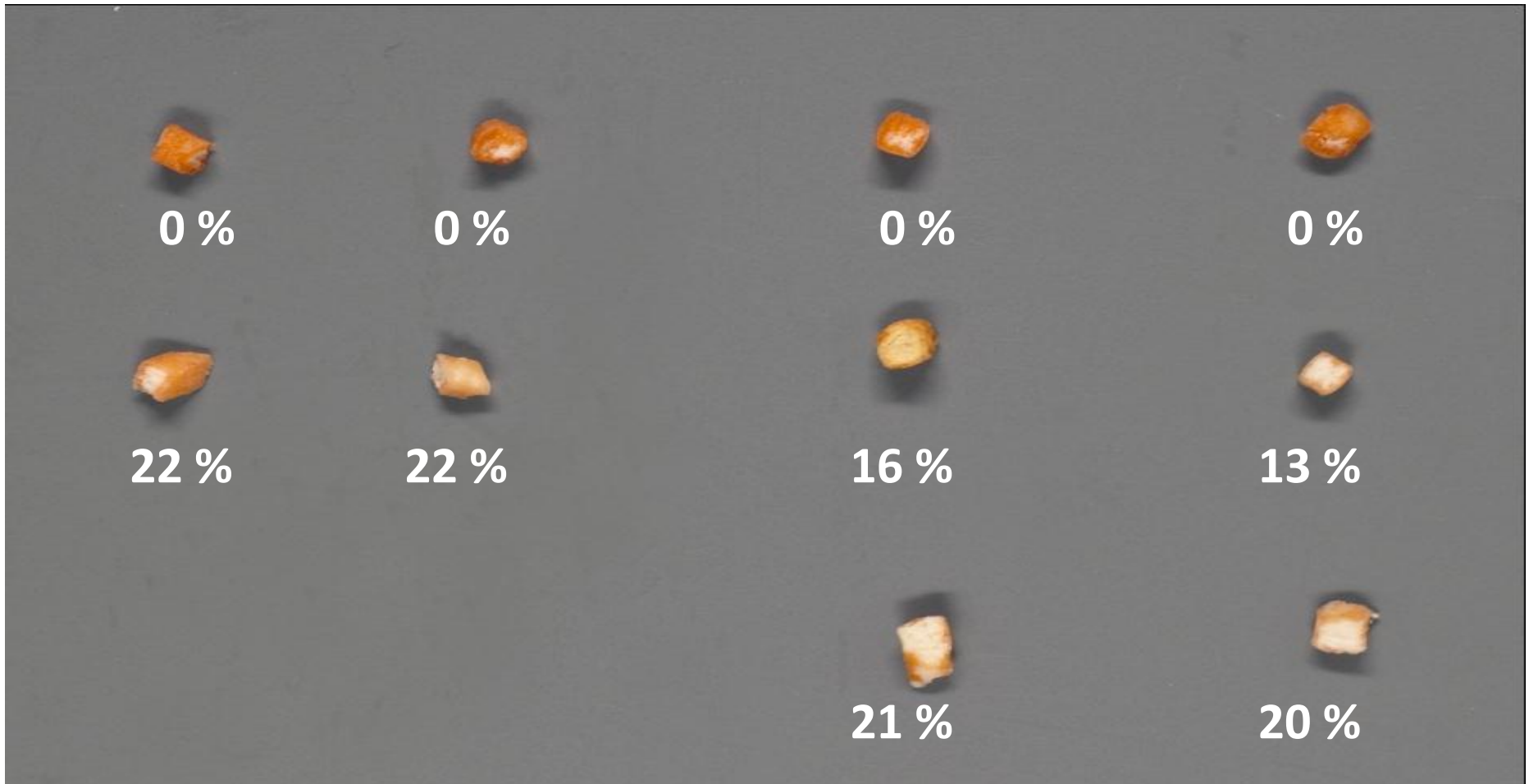

larger figures = larger reduction of oil uptake

# Reduction of Oil Uptake into Instant Noodles

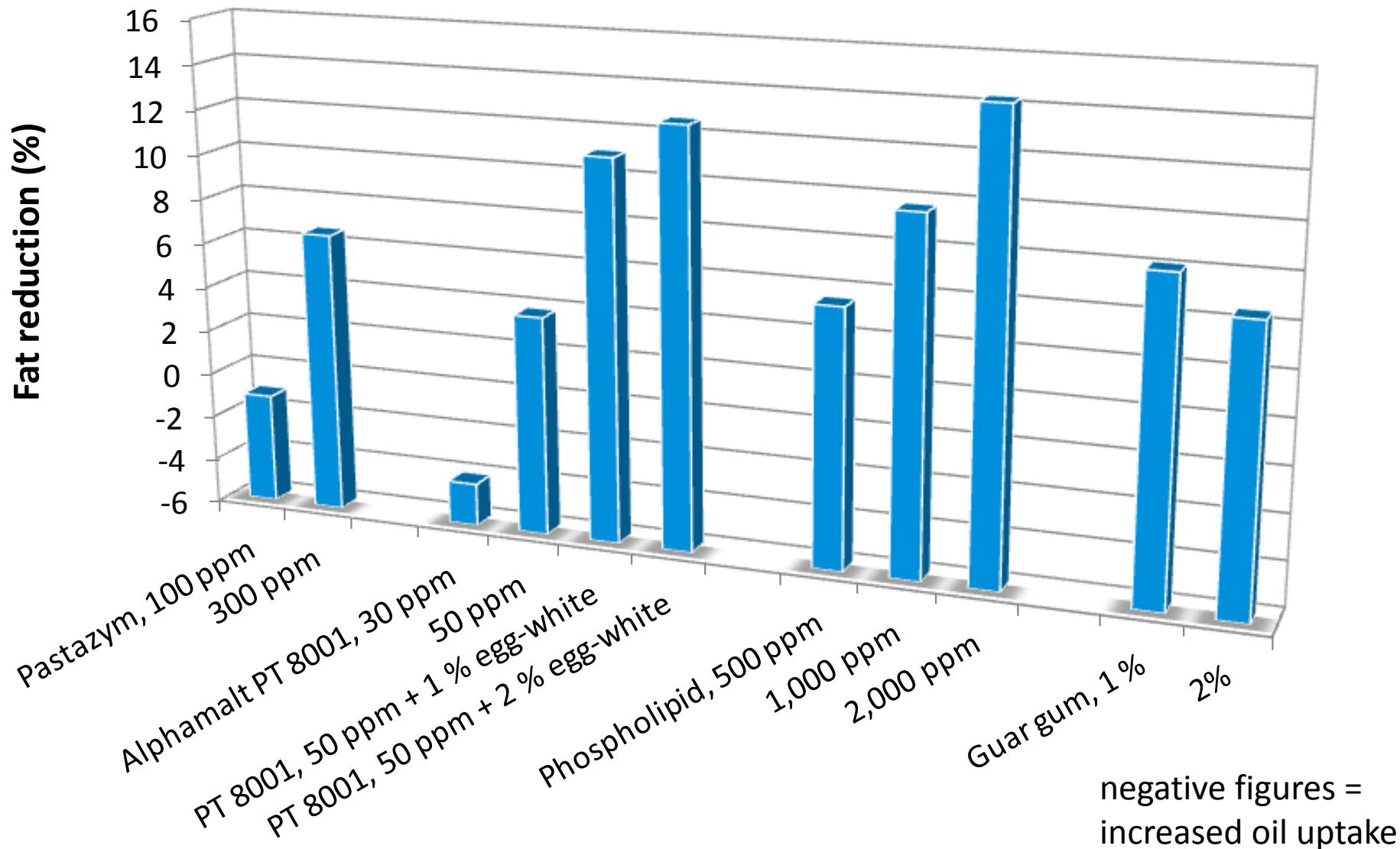

# Reduction of Oil Uptake into Instant Noodles by Synergistic Additive Compound

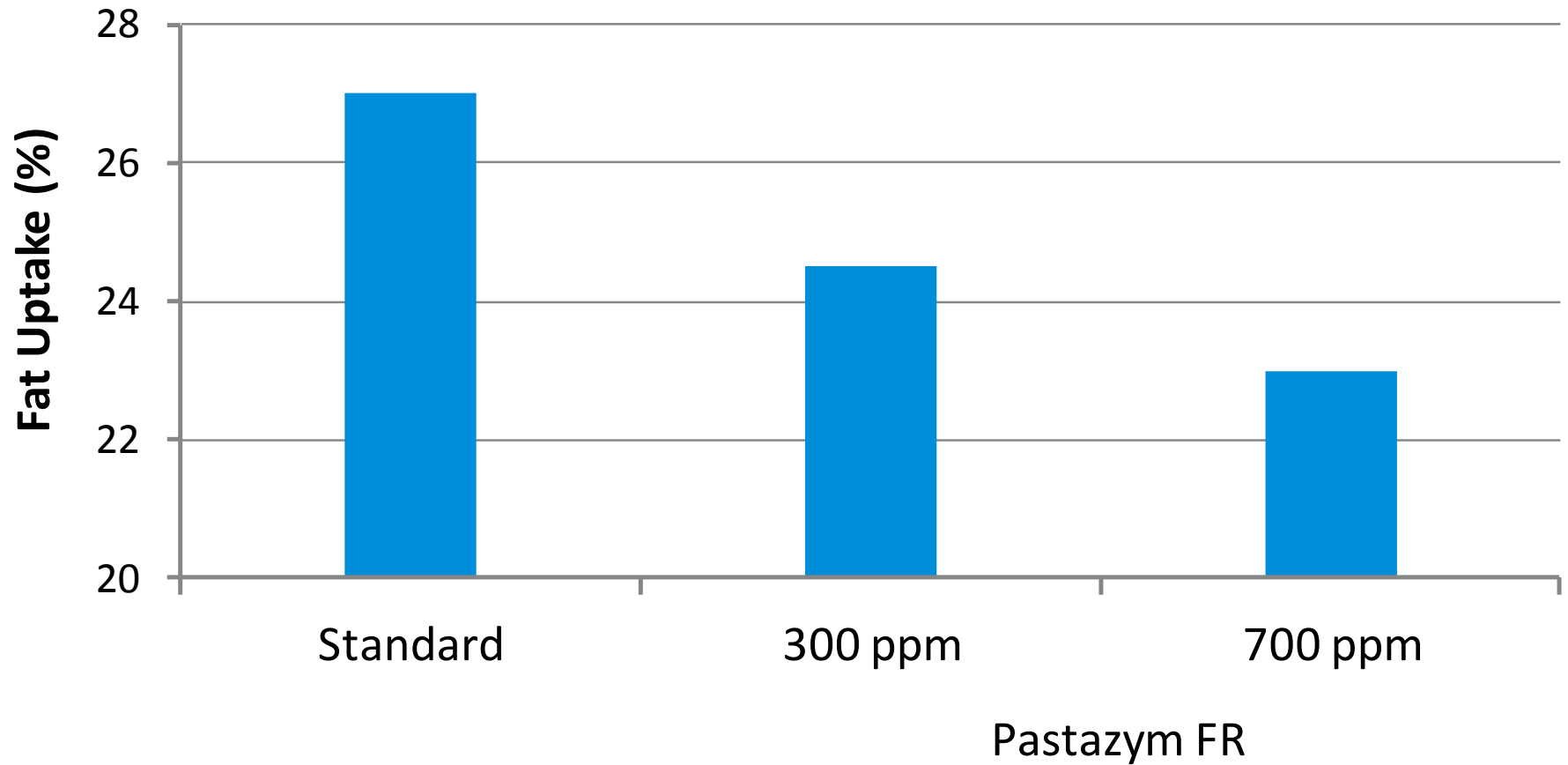



# Composite flour noodles

Wheat flour substitution by tapioca flour

# Improvement of the Colour of Dry Spaghetti from Composite Flour (95% wheat + 5% tapioca flour)



**200 ppm  
Pastazym  
BCT Plus**

**0.1%  
EMCEdur  
BCT ETH**

**Untreated**

# Improvement of the Colour of Dry Spaghetti from Composite Flour (80% wheat + 20% tapioca flour)



**200 ppm  
Pastazym  
BCT Plus**

**0.1%  
EMCEdur  
BCT ETH**

**Untreated**

# Improvement of the Colour of Cooked Spaghetti from Composite Flour (95% wheat + 5% cassava flour)



**Untreated**

**0.1% EMCEdur  
BCT ETH**

**200 ppm Pastazym  
BCT Plus**

# Improvement of the Texture of Cooked Spaghetti from Composite Flour

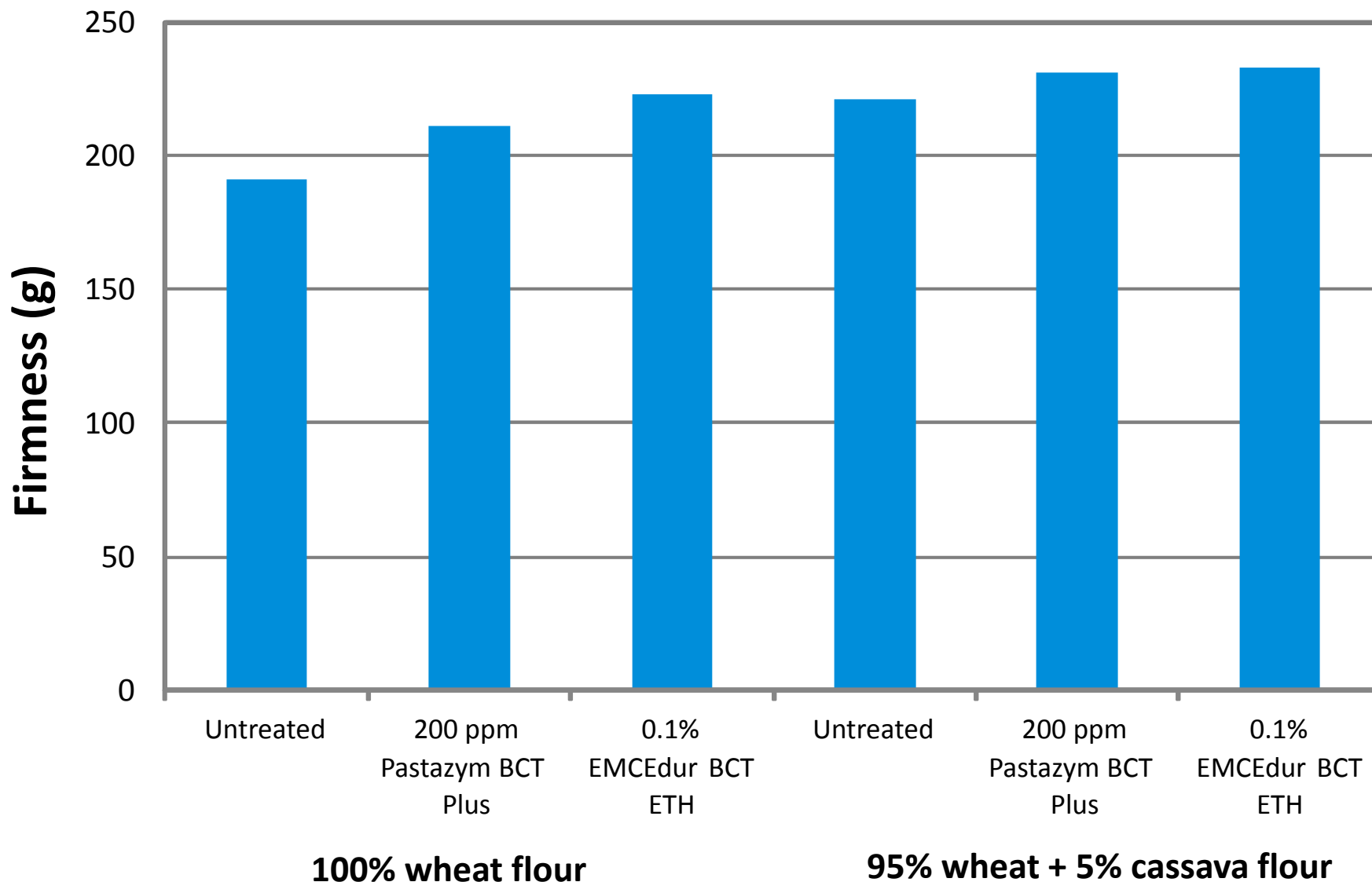

# Mühlentchemie GmbH & Co. KG

- a member of the Stern-Wywiol Group -

Kurt-Fischer-Str. 55  
22926 Ahrensburg, Germany  
+49 4102 202 001

[www.muehlenchemie.de](http://www.muehlenchemie.de)  
[www.stern-wywiol-gruppe.de](http://www.stern-wywiol-gruppe.de)



Leader in flour applications.